

Pressure Transducers and Transmitters

ASIC 'Performer'

20, 60, 100, 250, 400 and 700 bar



ASIC 'Performer'

Applications for the ASIC Performer

- Fork lift trucks - braking and load systems.
- Truck mounted cranes - load safety systems.
- Earth moving machinery - hydraulic gearbox control.
- Racing car - gearbox, fuel, cooling and suspension systems.
- Water usage systems - pressurised systems for industrial and hi-rise usage.
- Forest Machinery - felling and logging.
- Paper mills - speed control and weighing systems.



The Parker Filtration ASIC Performer Pressure Transducers and Transmitters.

To overcome the historical problems caused by “gauge creep” of thick film sensors and the fragility of peizo-electric/ceramic based sensors, the new ‘Performer’ range uses a high-grade stainless steel element, which is coated with layers of both insulative and alloy materials. These are trimmed to a very close tolerance using state of the art, semiconductor grade, laser and ion beam methods. This extremely accurate “front end” is then coupled with Application Specific Integrated

Circuitry (ASIC) to produce a sensor that is both accurate and repeatable over a wide, fully compensated, temperature range, -40°C to +125°C. The “Performer” is now available in a variety of thread-form and connector options.

This new design offers a high stability, very low drift device, which can operate over a wide thermal range. Powered from an extended working supply range (11-30Vdc {PTD} and 11-35Vdc {PTX}).



In addition to the standard 6 pressure ranges available, using the ASIC technology (Application Specific Integrated Circuit) programmable software, any variation can be manufactured. Consult Parker for any additional information.



A comprehensive range of Pressure Transducers and Transmitters are available from Parker Filtration.

- One-piece body and diaphragm machining ensures long-term product stability.
- All stainless steel construction.
- 6 transducer pressure ratings with 0-5Vdc and 1-6Vdc outputs.
- 6 transmitter pressure ratings with a 2-wire 4-20mA output.
- Micro plug and M12 connector options.



Specification

Pressure ranges:
20, 60, 100, 250, 400, 700 bar.

Maximum over pressure:
Rated pressure x2.

Maximum burst pressure:
Rated pressure x6.
Snubber fitted inside thread form.

Vibration:
>50g.

Installation:
Spanner size 22A/F.
Max. (recommended) tightening torque = 30Nm.

Preferred Thread Form Options

G¹/₄ (1/4BSP) with bonded seal.
All thread forms and sensor interface are made from 17-4PH stainless steel.
Non standard threads - contact Parker CMC

Electrical

Supply voltage

11 - 30Vdc
11 - 30Vdc
11 - 35Vdc

Transducer current draw = 8mA

Output

0 - 5Vdc
1 - 6Vdc
4 - 20mA

Linearity:
(over any 80°C temp range).
<+/-0.05%.

Hysteresis:
(over any 80°C temp range).
<+/-0.05% full scale.

Repeatability:
(over any 80°C temp range).
<+/-0.05% full scale.

Functional temp range:
-40°C to +125°C.

Temperature error:
(over any 80°C temp range) <1%.

Stability:
<0.1%FS after 1m cycles.

Response time:
<1mS.

Wiring Information

Micro DIN option

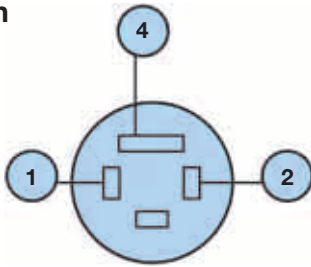

Micro DIN option		
Pin number	Transmitter	Transducer
1	N/A	Signal output
2	Supply +ve	Supply +ve
4	Return	Supply ref (0v)

M12 option

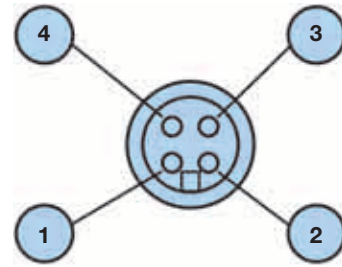

M12 option		
Pin number	Transmitter	Transducer
1	Supply +ve	Supply +ve
2	N/A	Signal output
3	Return	Supply ref (0v)
4	N/A	N/A

Installation Details

Micro DIN option

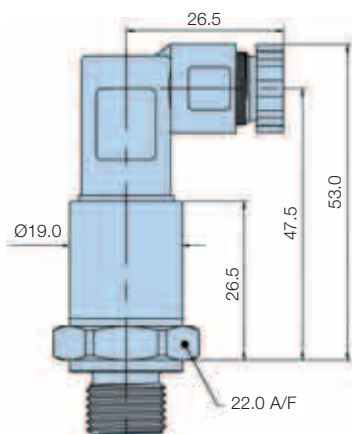

M12 option

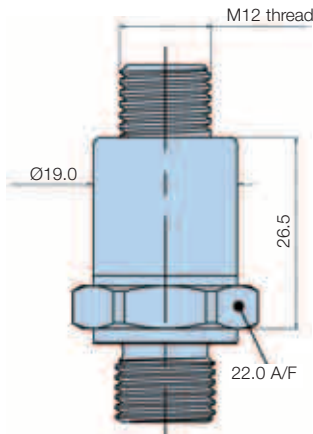

Flying lead option

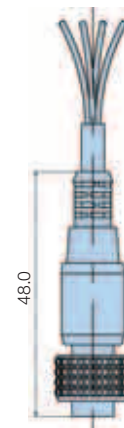

ASIC 'Performer'

Ordering Information

Standard products table

Product number	Description - pressure transducer	Model	Output	Pressure	Thread form	Connector
PTDVB2501A1C1	0 - 5 Vdc 250 bar 1/4 BSP bonded seal micro-din 43650	PTD	VB	250	1	A1C1
PTDVB4001A1C1	0 - 5 Vdc 400 bar 1/4 BSP bonded seal micro-din 43650	PTD	VB	400	1	A1C1
PTDVB2501A1C2	0 - 5 Vdc 250 bar 1/4 BSP bonded seal M12	PTD	VB	250	1	A1C2
PTDVB4001A1C2	0 - 5 Vdc 400 bar 1/4 BSP bonded seal M12	PTD	VB	400	1	A1C2
PTDVB0201A1C1	0 - 5 Vdc 20 bar 1/4 BSP bonded seal micro-din 43650	PTD	VB	020	1	A1C1
PTDVB0201A1C2	0 - 5 Vdc 20 bar 1/4 BSP bonded seal M12	PTD	VB	020	1	A1C2

Product number	Description - pressure transmitter	Model	Output	Pressure	Thread form	Connector
PTXB4001A1C2	4 - 20 mA 400 bar 1/4 BSP bonded seal M12	PTX	B	400	1	A1C2
PTXB0201A1C1	4 - 20 mA 20 bar 1/4 BSP bonded seal micro-din 43650	PTX	B	020	1	A1C1
PTXB0201A1C2	4 - 20 mA 20 bar 1/4 BSP bonded seal M12	PTX	B	020	1	A1C2
PTXB4001A1C1	4 - 20 mA 400 bar 1/4 BSP bonded seal micro-din 43650	PTX	B	400	1	A1C1
PTXB2501A1C1	4 - 20 mA 250 bar 1/4 BSP bonded seal micro-din 43650	PTX	B	250	1	A1C1
PTXB2501A1C2	4 - 20 mA 250 bar 1/4 BSP bonded seal M12	PTX	B	250	1	A1C2

Accessories

Product number	Supersedes	Description
P833PVC2M	P.833PVC-2M	2 meter PVC coated 4 core cable
P833PVC5M	P.833PVC-5M	5 meter PVC coated 4 core cable
P833PVC10M	P.833PVC-10M	10 meter PVC coated 4 core cable

Note 1: Part numbers featured with bold highlighted codes will ensure a 'standard' product selection.

Note 2: Alternate displayed part number selection will require you to contact Parker Filtration for availability.

Product configurator

Product number	Output options		Pressure range (bar)		Thread form		Connector	
	PTD	VB	0 - 5 Vdc	020	0 - 20	1	1/4 BSP with bonded seal	A1C1
PTX	SB	1 - 6 Vdc	060	0 - 60			A1C2	M12
	B	4 - 20mA (PTX only)	100	0 - 100				
	RB	0.5 - 4.5 ratiometric	250	0 - 250				
	PB	0.1 - 4.9	400	0 - 400				
			700	0 - 700				

Note 1: Part numbers featured with bold highlighted codes will ensure a 'standard' product selection.

Note 2: Alternate displayed part number selection will require you to contact Parker Filtration for availability.

Examples of standard part number product ordering

PTXB0201A1C2 4 – 20mA output transmitter
 20 bar maximum pressure
 1/4" BSP with bonded seal
 M12 connector
 (See cable selection for IP68 protection)

PTDVB2501A1C1 0 – 5 volt output transducer
 250 bar maximum pressure
 1/4" BSP with bonded seal
 DIN43650 connecting plug