



Tanktop Mounted Suction & Return Line Filters - Types SR1 & SR2

Suction Return Series

MAX 250 l/min - 10 bar

AN INNOVATIVE GREEN
FILTER FEATURING
LEIF®



Suction Return Series

Features & Benefits

Features	Advantages	Benefits
Compact design	Less space required to apply SR Series	Improved flexibility during system design
Bypass valve mounted in series with back-pressure valve	Pressurisation of filtered oil for hydrostatic drive ensured during bypass	Lower risk of pump cavitation No direct bypass in the tank reducing the additional risk of oil foaming
LEIF® elements	Patented element safeguards the use of genuine parts	Guaranteed quality of filtration Contributes to ISO 14001 certification
Strainer located in filter head	Strainer filters all bypass fluid by using a system-matched degree of filtration	Improved protection of system Strainer can be inspected and cleaned during service events
High level of customisation	Dedicated system-matched solutions can be easily made available	Improved integration of filter in system combined with lower initial system costs
Full flow bypass with low hysteresis	Reduction of bypass period due to low hysteresis Only a small part of the total flow is bypassing the element	Improved protection of system
Standard or customised funnel	Ensures that oil enters the tank under the oil level	Significant reduction of oil foaming
Multiple ports availability	Flexibility related to suction- and return line hose(s) arrangement	More compact solutions can be realised The use of manifold blocks can be avoided Easy to integrate with cooler circuit

Typical Applications

Mobile equipment with both open and closed hydraulic circuits. For example:

- Road sweepers
- Road rollers
- Fork lift trucks
- Loading shovels
- Telescopic handlers
- Dump trucks
- Skid steers
- Agricultural harvesting machines
- Mini excavators

The Parker Filtration Tank Top Mounted Suction & Return Line Filters.

A tank top mounted return filter capable of feeding filtered oil under positive pressure to the suction side of the boost pump, thereby filtering both open and closed loop oil systems through one filter. The Parker SR filters use the patented LEIF® element for environmental-friendly filtration and offers protection against the use of pirate elements. Several options including integrated suction strainer and dipstick are available.

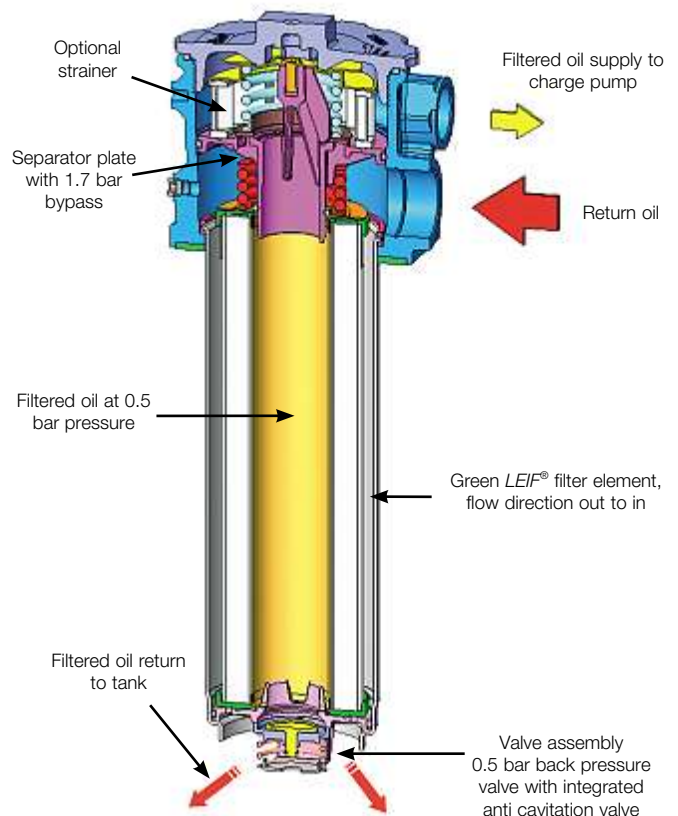

Specification

Pressure ratings:

Max. 10 bar.

Assembly:

Tank top mounted filters.

Connections:

Return port G1 (to BS 2779).
Suction port G $\frac{3}{4}$ (to BS 2779). } SR1

Return port G1 $\frac{1}{4}$ (ISO 228) or SAE20:
Optional second return port type SR2.
Suction port G1 (ISO 228) or SAE16:
Standard two suction ports. } SR2

Seal material:

Type SR1 – Nitrile.
Type SR2 – Nitrile, Fluoroelastomer.
Other seal material on request.

Operating temperature range:

-30° to +110°C.

Bypass valve system:

Main system bypass valve.
Type SR1 – 1.7 bar (2.5 bar optional).
Type SR2 – 1.7 bar (2.5 bar optional).

Degree of filtration:

Determined by multipass test according to ISO 16889.

Flow fatigue characteristics:

Filter media designed to optimise fatigue life.

Filtration media:

Type SR1 and SR2 –
Ecoglass III for *LEIF*[®] elements. See table 1 and 2 on the following page.
- High dirt holding capacity.
- Low pressure drop.
- Extended service life.

Element collapse rating:

Type SR1 – 10 bar (ISO2941).
Type SR2 – 10 bar (ISO2941).

Suction line:

Back-pressure valve setting 0.5 bar (nominal).

Anti-cavitation:

Emergency suction valve fitted as standard.

Construction:

Type SR1 and Type SR2

Precision pressure die casting

Filter

Housing:

Cover:

Glass reinforced nylon (high impact and temperature resistant)

Weight:

1.4Kg 3.3Kg

Filter

element:

LEIF[®] element with reusable metal element sleeve.

The patented *LEIF*[®] concept contributes to ISO14001

and can be applied with mineral and HEES type fluids. } SR1

For other fluid types consult Parker Filtration. } & SR2

Circuit Application Example

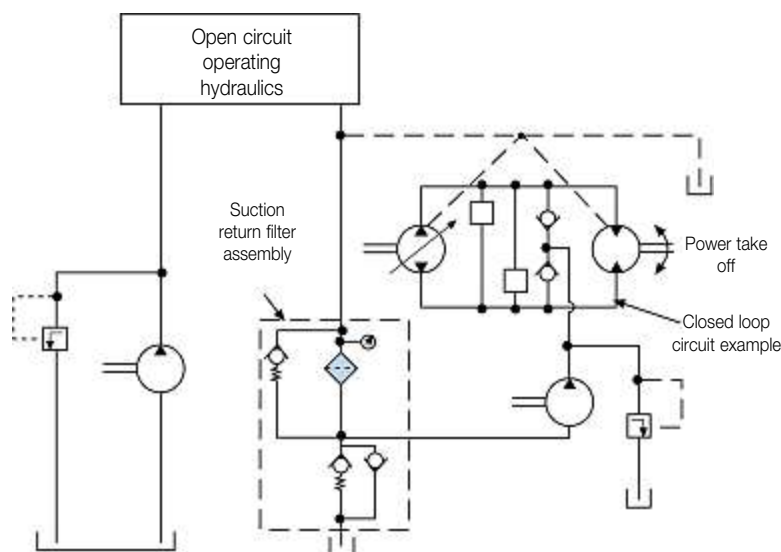

Note: Suction return filter without optional strainer.

Suction Return Filter: Hydraulic Circuit

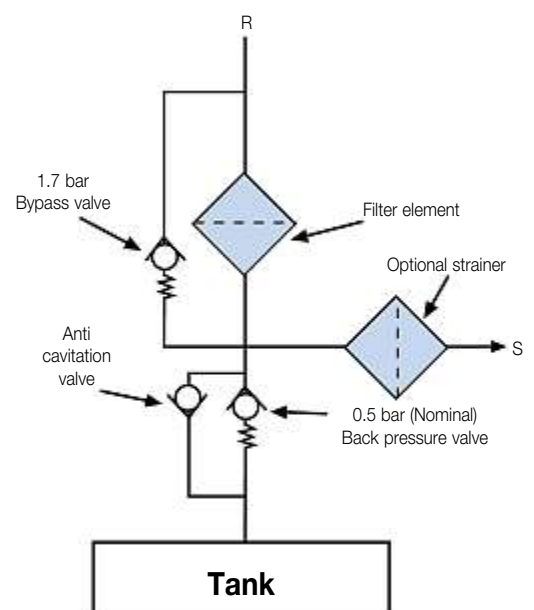

Note: Suction return filter with optional strainer.

Suction Return Series

SR1

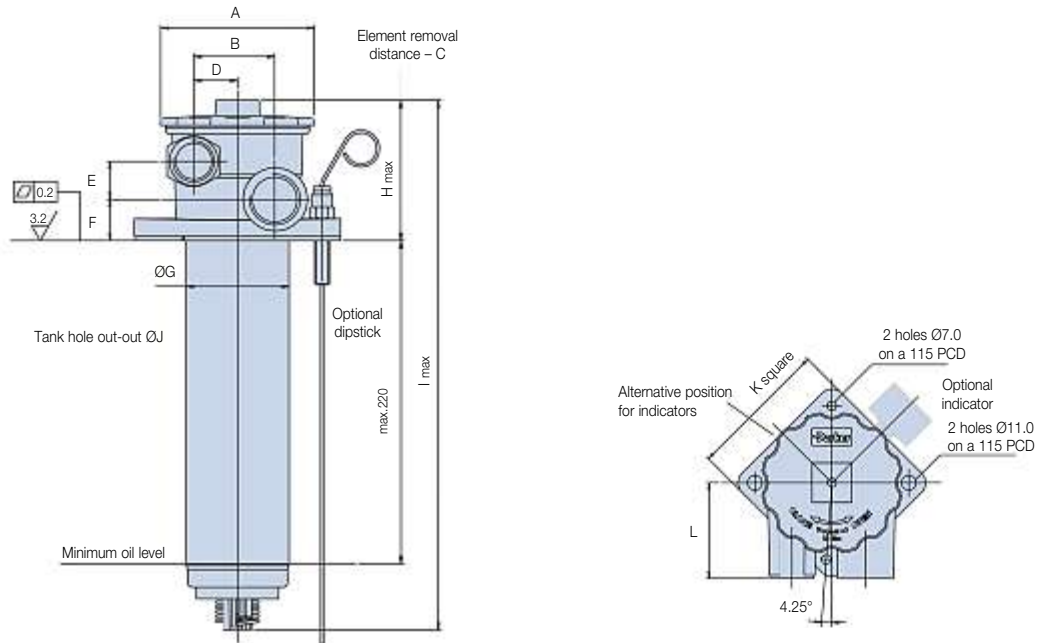

SR2

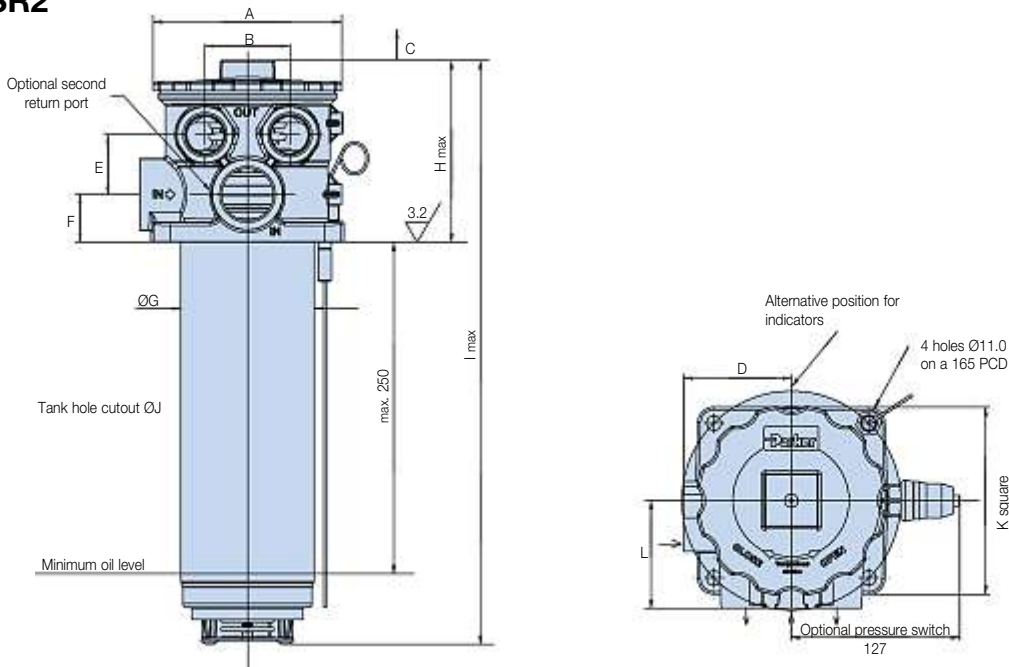

Dimensions mm (inches)	A	B	C	D	E	F	G	H	I	J	K	L
Type SRL1	106 (4.17)	55 (2.17)	280 (11.0)	29.75 (1.17)	26 (1.02)	28 (1.10)	70 (2.76)	96 (3.78)	361 (14.21)	71 to 73 (2.8 to 2.87)	105 (4.13)	72 (2.83)
Type SRL2	142 (5.59)	64 (2.52)	380 (14.96)	81 (3.19)	45 (1.77)	36 (1.42)	100 (3.94)	137 (5.39)	440 (17.32)	101 to 103 (3.98 to 4.06)	145 (5.71)	81 (3.19)

Element removal distance for dimension C.

Indicator Details

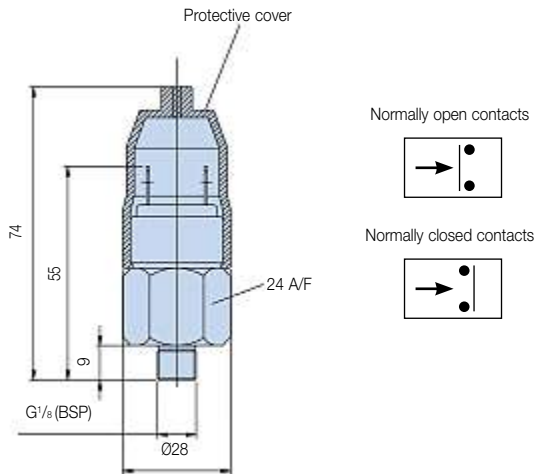

Visual indicator	2 bar
Thread connection	G $\frac{1}{8}$
Code	FMUG5HBMG02L

Pressure switch	
Elec.rating	42V / 2A
Thread connection	G $\frac{1}{8}$
Elec.connection	AMP terminal 6.3 x 0.8
Protection	IP65 (terminal IP00)
Setting	2 bar
Switch type	NO or NC
Code	FMUS6HBMG02L (NO switch)
	FMUS7HBMG02L (NC switch)

Note: Vacuum indicators visual or electrical are available on request for filter type SR2 only.

Principles of Operation

Suction Return Series filter

This one filter assembly is designed to carry out two specific functions:

- (1) Filter system return line oil.
- (2) Supply filtered oil under positive pressure to the closed loop hydrostatic circuits.

Principles of operation

- (1) Return oil from both the open and closed circuits* is fed into the Suction Return Series Filter at port 'R'.
- (2) The filtered oil is maintained at a nominal 0.5 bar by the unique back pressure valve assembly and fed into the closed loop hydrostatic circuit via port 'S'.
- (3) Surplus filtered oil is fed back to the tank via the back pressure valve assembly.
- (4) Emergency suction (anti-cavitation) valve: This valve is fitted as standard to ensure oil is always available to the closed loop system, even on emergency occasions when the return flows do not meet the flow demands of the closed loop circuit.

Additional installation guidance notes

- (1) Return oil flow should always be greater than the oil flow rate demanded by the closed loop charge pump.
- (2) Oil level at all times should not fall below valve assembly at the base of the filter bowl.

Benefits

- (1) Only one filter is required to supply filtered oil to both open and closed loop circuits.
- (2) Feeding the closed loop circuit with filtered oil at a nominal pressure of 0.5 bar ensures excellent cold start characteristics, thus reducing the risk of cavitation.
- (3) Four hole mounting with gasket seal.
- (4) Microglass III filter element materials ensure; low pressure drop, high dirt holding capacity and extended service life.
- (5) Type Parker SR filters with patented *LEIF*[®] element, unique drain construction, quick element replacement concept.

*CAUTION:

Back pressure in pump and motor drain lines should always be kept at a minimum thus protecting shaft seals etc.

If case drain oils are to be fed through the return line filter please consult the pump/motor manufactures for details on maximum allowable back pressure.

Ensure filter elements are replaced when element condition indicators show that the bypass setting has been reached.

Failure to observe the above operation and guidance notes, or use of non genuine Parker specified filter elements could cause damage to the system. System designers should always ensure that adequate cooling capacity is available.

Suction Return Series

Pressure Drop Curves (Type SR1)

The recommended level of the initial pressure drop is approximately 1 bar.
 If the medium used has a viscosity different from 32cSt, pressure drop over the filter can be estimated as follows:
 The total $\Delta p = \text{Housing } \Delta p_h + (\text{Element } \Delta p_e \times \text{working viscosity}/32)$.

SRL1 Empty Housing (Length Code 2)

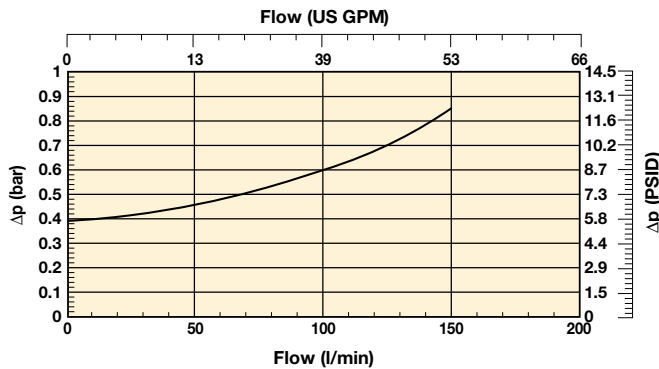

SRL1 (Element Length Code 2)

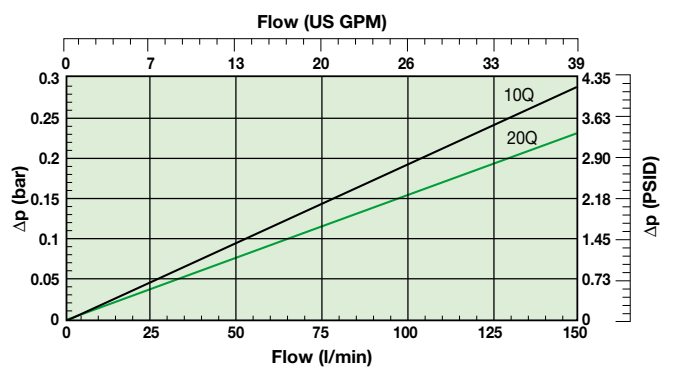

Curves are based on 32cSt fluid viscosity and 0.87 Kg/l density.

Pressure Drop Curves (Type SR2)

Curves are based on 32cSt fluid viscosity and 0.87 Kg/l density.

SRL2 Empty Filter Housing

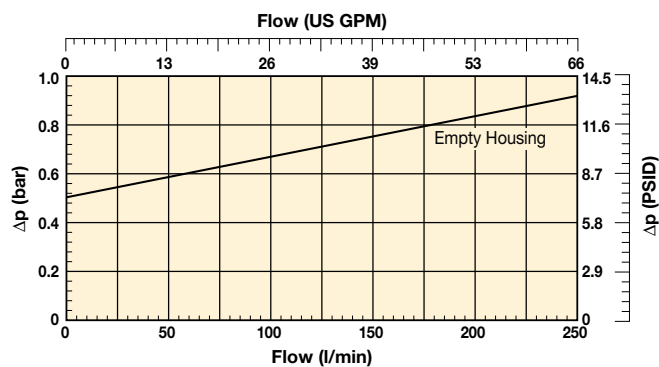

SRL2 Filter Element Length 2

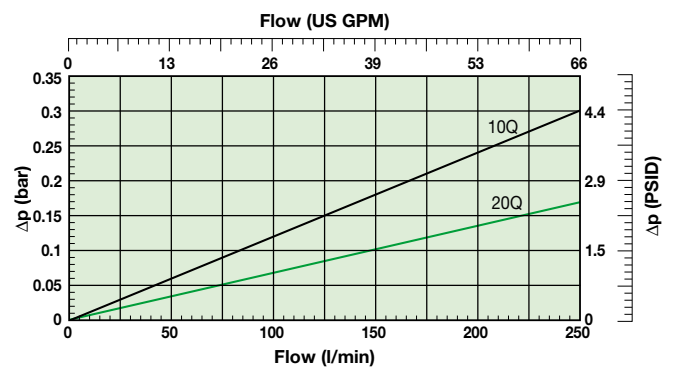

Ordering Information

Standard products table

Part number	Supersedes	Flow (l/min)	Model number	Element length	Media rating (µ)	Seals	Indicator	Bypass settings	Ports return	Ports suction	Included options	Replacement elements	Supersedes
SRL1210QLBPGG161		130	SRL1	Length 2	10	Nitrile	Plugged	1.7 Bar (25 Psi)	G1	G ¹ / ₂	None	937984Q	SRE12Q10
SRL1220QLBPGG161		130	SRL1	Length 2	20	Nitrile	Plugged	1.7 Bar (25 Psi)	G1	G ¹ / ₂	None	937985Q	SRE12Q20
SRL2210QLBPGG201	SRL22Q10NP1B10	250	SRL2	Length 2	10	Nitrile	Plugged	1.7 Bar (25 Psi)	G1 ¹ / ₂	2xG1 ¹ / ₂	None	937946Q	SRE22Q10
SRL2220QLBPGG201	SRL22Q20NP1B10	250	SRL2	Length 2	20	Nitrile	Plugged	1.7 Bar (25 Psi)	G1 ¹ / ₂	2xG1 ¹ / ₂	None	937947Q	SRE22Q20

Note: Filter assemblies ordered from the product configurator below are on extended lead times. Where possible, please make your selection from the table above.

Product configurator

Configurator example SR filter

Box 1	Box 2	Box 3	Box 4	Box 5	Box 6	Box 7	Box 8
SRL2	2	05QL	B	S6	G	2G20	I

Box 1

Code	
Model	Code
SR1 Series with LEIF[®] element	SRL1
SR2 Series with LEIF[®] element	SRL2

Highlights Key (Denotes part number availability)

123	Item is standard
123	Item is standard green option
123	Item is semi standard
123	Item is non standard

Note: Standard items are in stock, semi standard items are available within four weeks

Box 2

Filter type	
Housing	Code
Reduced length	on request
Standard length	2
Extended length	on request

Box 3

Degree of filtration				
Element	LEIF[®]			
	Q3 glassfibre βx(c) >200			
	Code	Code	Code	Code
LEIF[®]	02QL	05QL	10QL	20QL

Box 4

Seal type	
Seal material	Code
Nitrile	B
Fluoroelastomer	V

Box 5

Indicator	
	Code
Pressure gauge, setting 2.0 bar, G ¹ / ₂	G5
Pressure switch 42V, 2.0 bar setting, NO with G ¹ / ₂ BSP	S6
Pressure switch 42V, 2.0 bar setting, NC with G ¹ / ₂ BSP	S7
Pressure switch 250V, NO/NC with G ¹ / ₂	on request
No indicator, indicator ports not machined	N
No indicator, indicator port R plugged	P
No indicator, indicator ports L + R plugged	on request
Vacuum switch / vacuum gauge	on request
Other settings for indicators / gauges on request	on request

Box 6

Bypass valve	
Bypass valve	Code
1.7 bar	G
2.5 bar	I
Blocked bypass	on request
Other bypass settings	on request

Box 7

Filter connection			
Ports	Code	Note	
Return port 1 x G1 (ISO228) + Suction port 1 x G ¹ / ₂ (ISO228)	G16	SRL1	
Return port 1 x G1 ¹ / ₂ (ISO228) + Suction port 2 x G1 (ISO228)	G20	SRL2	
Return port 2 x G1 ¹ / ₂ (ISO228) + Suction port 2 x G1 (ISO228)	2G20	SRL2	
Return port 1 x SAE20 + Suction port 2 x SAE16	S20	SRL2	
Return port 2 x SAE20 + Suction port 2 x SAE16	2S20	SRL2	

Box 8

Options	
Options	Code
None	1
Strainer 120 micron	G
Dipstick	6
Plugged vent port in cover	H
Strainer 120 micron, dipstick and plugged vent port	I
Customized options	on request

Degree of filtration						Media code
Average filtration beta ratio β (ISO 16889) / particle size µm [c]						
βx(c)=2	βx(c)=10	βx(c)=75	βx(c)=100	βx(c)=200	βx(c)=1000	
% efficiency, based on the above beta ratio (βx)						
50.0%	90.0%	98.7%	99.0%	99.5%	99.9%	
N/A	N/A	N/A	N/A	N/A	4.5	
N/A	N/A	4.5	5	6	7	02Q/02QL
N/A	6	8.5	9	10	12	05Q/05QL
6	11	17	18	20	22	10Q/10QL
						20Q/20QL

Spare elements		
Replacement elements	Supersedes	
937942Q	SRR12Q05N	Semi standard
937943Q	SRR12Q10N	Standard
937944Q	SRR12Q20N	Standard
937945Q	SRE22Q05	Semi standard
937946Q	SRE22Q10	Standard
937947Q	SRE22Q20	Standard
937983Q	SRE12Q05	Semi standard
937984Q	SRE12Q10	Standard
937985Q	SRE12Q20	Standard

Note 1: Part numbers featured with bold highlighted codes will ensure a 'standard' product selection.

Note 2: Alternate displayed part number selection will require you to contact Parker Filtration for availability.