

Tanktop Mounted Return Line Filters

# TTF Series

MAX 500 l/min - 10 bar

AN INNOVATIVE GREEN  
FILTER FEATURING  
**LEIF**®



# TTF Series

## Features & Benefits

Features	Advantages	Benefits
10 bar rated filter	Can be utilised for severe return line applications	Reduced downtime due to premature filter failures
Cast aluminium head	Compact profile, lightweight and durable	Less weight, smaller envelop and cleaner appearance
LEIF® elements	Patented element safeguards the use of genuine parts	Guaranteed quality of filtration Contributes to ISO 14001 certification
Magnetic pre-filtration	Removes ferro particles, even during bypass conditions	Improved fluid cleanliness levels Extended element life time
In-to-Out filtration	All captured contamination retains inside the element	No recontamination of system during change of elements
High level of customisation	Dedicated system-matched solutions can be easily made available	Improved integration of filter in system combined with lower initial system costs
Full flow bypass with low hysteresis	Reduction of bypass period due to low hysteresis	Improved protection of system
	Only a small part of the total flow is bypassing the element	
Standard or customised funnel	Ensures that oil enters the tank under the oil level	Significant reduction of oil foaming

## Typical Applications

- Waste management trucks
- Mobile cranes
- Power packs
- Wheeled loaders
- Drilling equipment

### The Parker Filtration TTF Series Return Line Filters

TTF tank top mounted return line filters feature pre-filtration by means of a magnet column and a full flow bypass with low hysteresis. Thanks to the “In-to-Out” filter principle, contaminated oil cannot leak back into the system. TTF filters are available in versions capable of handling flow rates up to 500 l/min. They can operate up to a maximum working pressure of 10 bar. Optional filling port in filter cover, second return port and customised diffusers can be specified. Manifold type filter head (TSR Series) with four return ports is also available.



## Specification

### Operation pressure:

Max. 10 bar.

### Assembly:

Tank top mounted.

### Connections:

Threaded BSP ports.  
Flanged ports on request.  
Manifold filter head type TSR on request available for flows up to 250 l/min.

### Filter housing:

Aluminium head and cover.

### Seal material:

Nitrile, fluoroelastomer, neoprene.

### Operation temperature range:

-40 to +120°C.

### Bypass setting

Opening pressure 0.8 / 1.5 or 2 bar.  
Other settings on request.

### Degree of filtration:

Determined by multipass test according to ISO 16889.

### Flow fatigue characteristics:

Filter media is supported so that the optimum fatigue life is achieved.

### Filtration media:

Microglass III and Ecoglass III for *LEIF*<sup>®</sup> elements.  
Also available 10µm cellulose and 40µm stainless steel mesh.

### Element collapse rating:

10 bar (ISO 2941)

### Pressure indicator options:

Setting 0.7 or 1.2 bar.  
Other settings on request.  
Visual pressure gauge.  
Electrical pressure switch.

### Options:

Diffuser with and without (type P) perforated flow area for optimum flow path in the reservoir.

### Magnetic pack:

Standard.

### Filling port in cover: (optional)

Plugged.

### Filter element:

*LEIF*<sup>®</sup> element with reusable metal element sleeve.  
Optional conventional style element with steel end caps.  
The *LEIF*<sup>®</sup> element is patented and safeguards the use of genuine parts.  
Note: *LEIF*<sup>®</sup> element can be used with mineral and HEES type oils.  
For other fluids consult Parker Filtration.  
*LEIF*<sup>®</sup> contributes to ISO 14001 quality standards.

## TTF

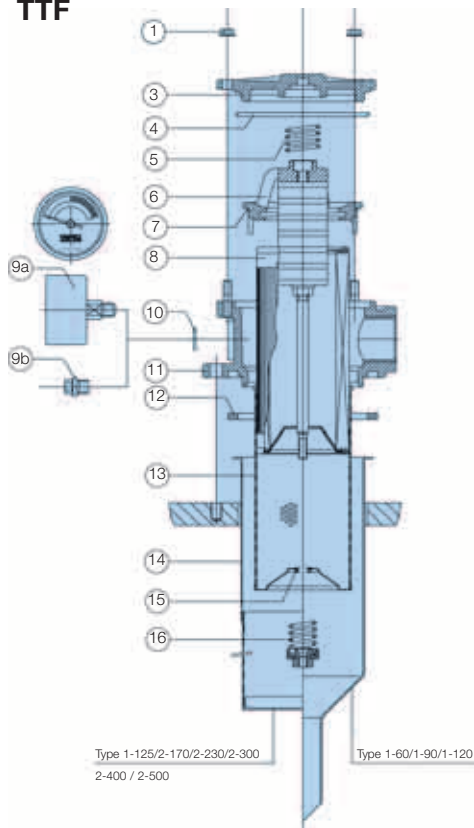

## TSR

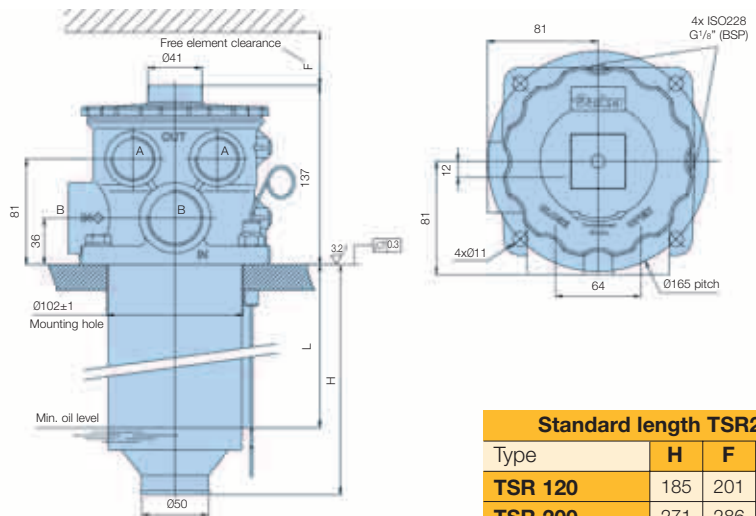

### Standard length TSR2

Type	H	F	L
TSR 120	185	201	150
TSR 200	271	286	286
TSR 250	404	421	369

Dimensions in mm

### Ports A

Ports A	Ports B
G1 (BSP)	G1¼ (BSP)
SAE16	SAE20

Note: All ports for return flow only

### Technical specification

Max nominal return flow	120-200-250 l/min
Max working pressure	10 bar
Temperature range	-30°C to +100°C
Bypass pressure	1,5 bar
<i>LEIF</i> <sup>®</sup> -filtration ratio	2µ/5µ/10µ/20µ
Seals	NBR
Options	Dipstick Indicator (electrical/visual)

### TTF sealkit: No. 4+7+12

Ref.	No.	Description
1	4	Flange nut
3	1	Cover
4	1	Cover-seal
5	1	Top-spring
6	1	Insert
7	1	Insert-seal
8	1	Element
9a	0-1	Indicator
9b	0-3	Plug M10x1
10	0-3	Unit-ring
11	1	Housing
12	1	Gasket
13	1	Sleeve
14	1	Funnel/diffuser
15	1	O-ring
16	1	Bypass set

# Tanktop Mounted Return Line Filters

# TTF Series

## Specification (cont.)

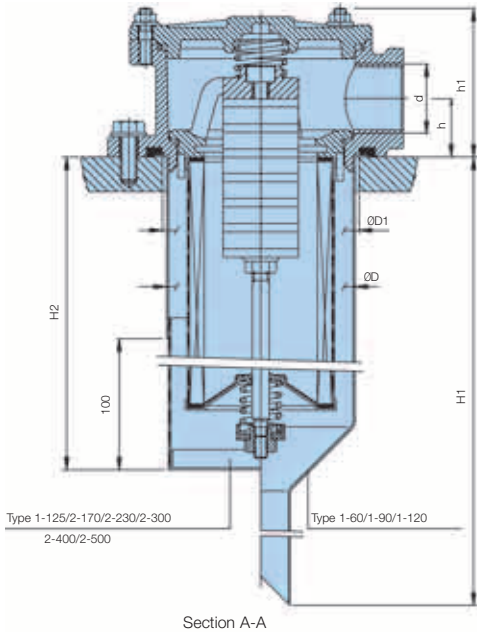

Section A-A

with funnel

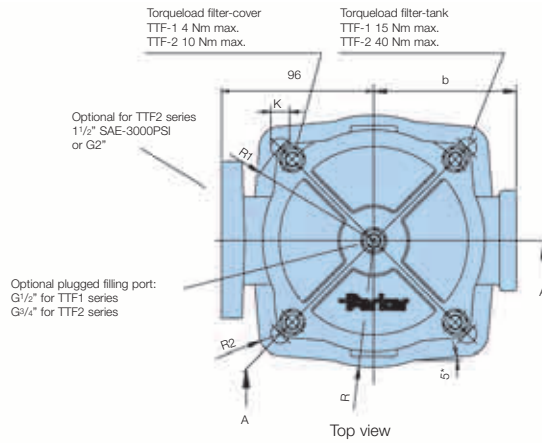

Top view

Note: TTF2-400 and TTF2-500 are standard supplied without magnets

Type	d=BSP	h	h1	ØD	ØD1	H1	H2	b	R	R1	R2	K
TTF60	G1/2, G3/4, G1	28	73	Ø90	Ø93	230	68	60	63	10	4xØ9	
TTF90						280						
TTF120						330						
TTF125						420						
TTF170	G1 1/4, G1 1/2	36	92	Ø132	Ø136	305	90	83	87.5	12	4xØ11	
TTF230						305						
TTF300						510						
TTF400						525						
TTF500						575						

Dimensions in mm

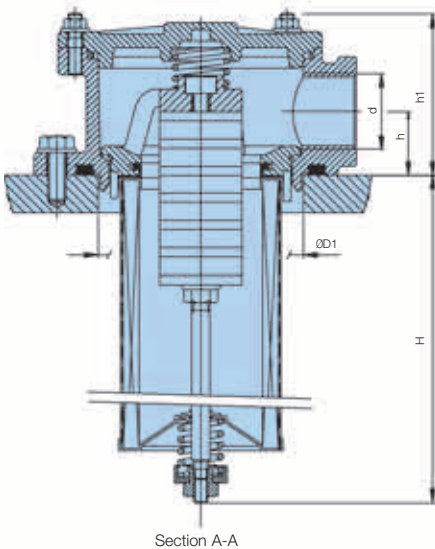

Section A-A

without funnel

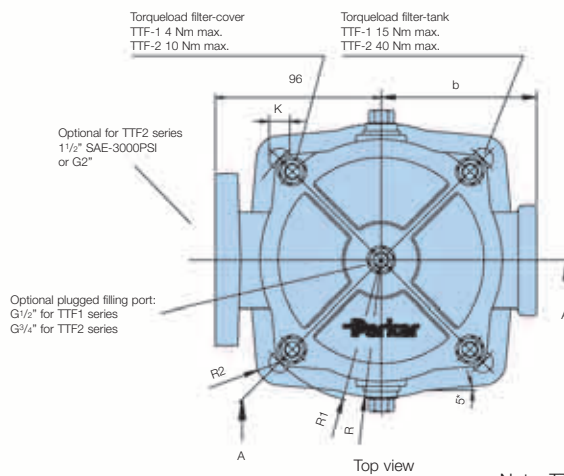

Top view

Note: TTF2-400 and TTF2-500 are standard supplied without magnets

Type	d=BSP	b	ØD1	h	h1	H	R	R1	R2	K
TTF60	1/2", 3/4", 1"	68	Ø91	28	73	131	60	63	10	4xØ9
TTF90						175				
TTF120						225				
TTF125						325				
TTF170	1 1/4", 1 1/2"	90	Ø134	36	92	223	83	87.5	12	4xØ11
TTF230						303				
TTF300						508				
TTF400						523				
TTF500						558				

Dimensions in mm

## Pressure Drop Curves

The recommended level of the initial pressure drop for low pressure filters is max 0.5 bar.

If the medium used has a viscosity different from 32cSt, pressure drop over the filter can be estimated as follows:

$$\Delta p = (\Delta p_{32} \times \text{viscosity of medium used}) / 32\text{cSt}$$

**TSR II-120 Filter Element Length 1**

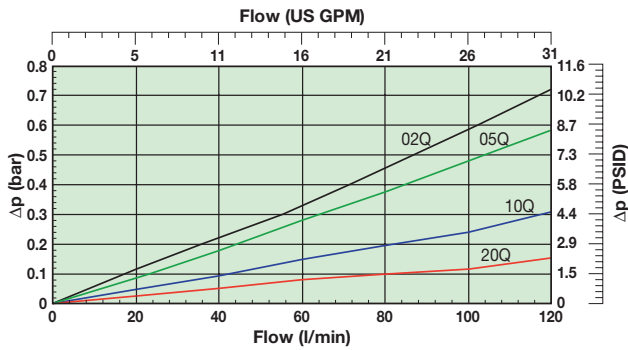

**TSR II-200 Filter Element Length 1**

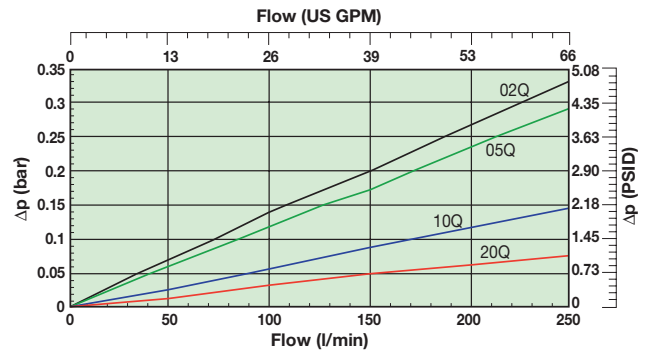

**TSR II-250 Filter Element Length 3**

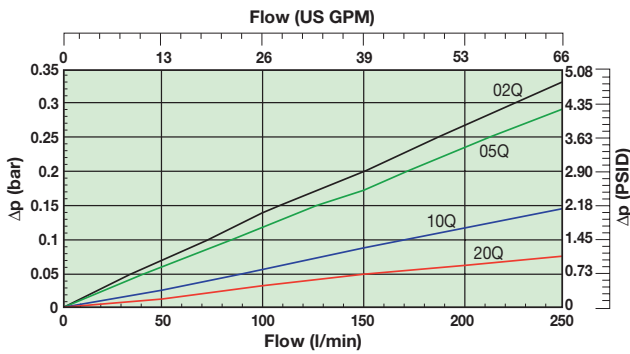

**TTF 1-60 Filter Element Length 2**

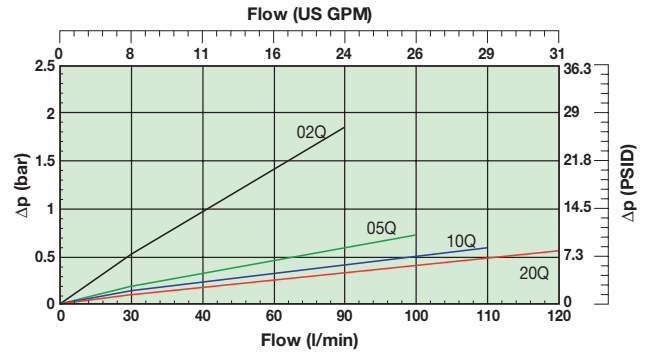

**TTF 1-90 Filter Element Length 3**

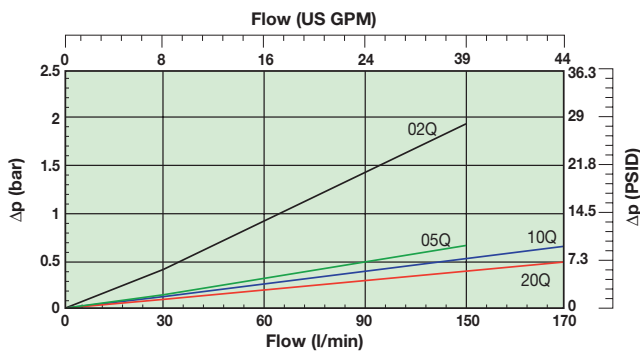

**TTF 1-120 Filter Element Length 4**

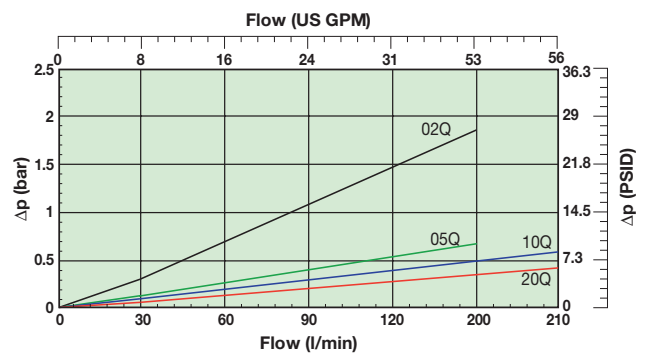

**TTF 1-125 Filter Element Length 5**

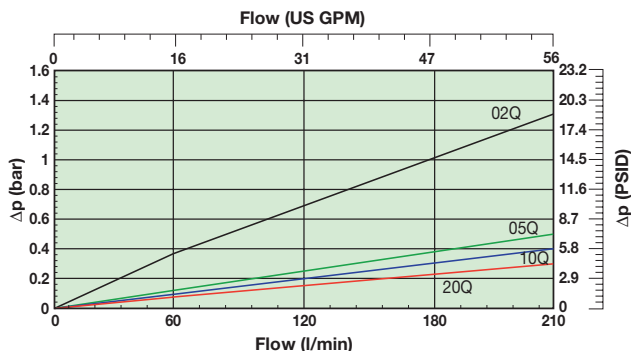

# TTF Series

## Pressure Drop Curves (cont.)

The recommended level of the initial pressure drop for low pressure filters is max 0.5 bar.

If the medium used has a viscosity different from 32cSt, pressure drop over the filter can be estimated as follows:

$$\Delta p = (\Delta p_{32} \times \text{viscosity of medium used}) / 32\text{cSt}$$

**TTF 2-170 Filter Element Length 6**

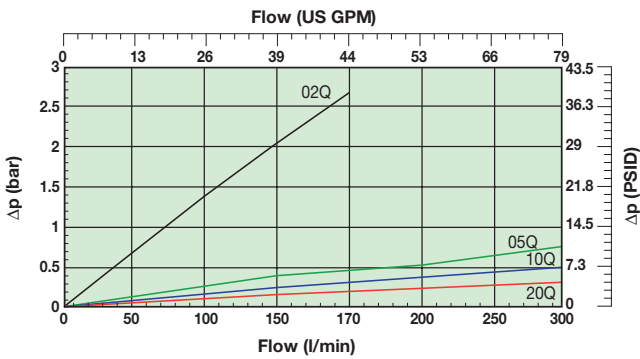

**TTF 2-230 Filter Element Length 7**

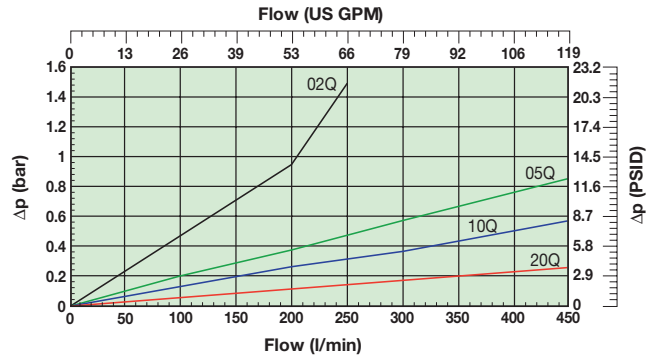

**TTF 2-300 Filter Element Length 8**

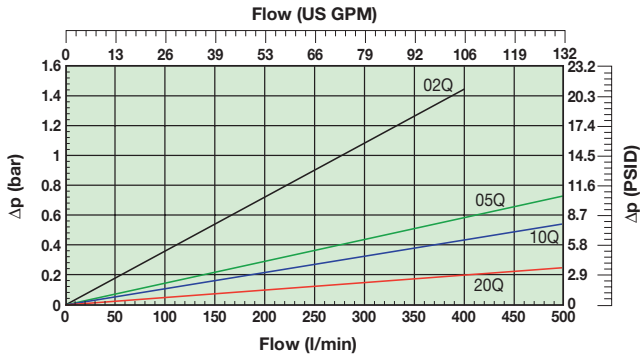

**TTF 2-400 Filter Element Length 9**

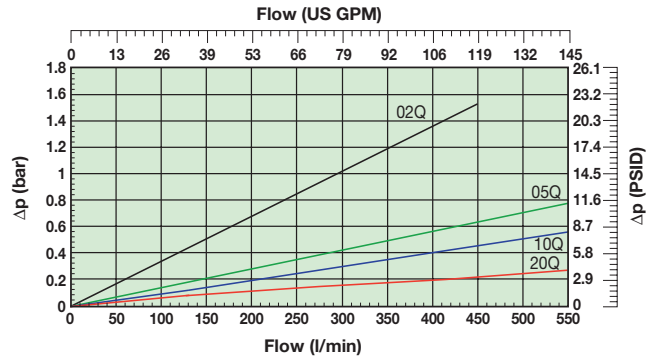

**TTF 2-500 Filter Element Length 10**

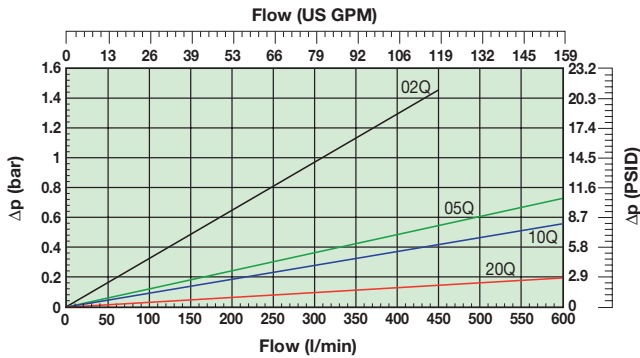

**TTF60 Filter Element Length 2  
Cellulose & stainless steel media**

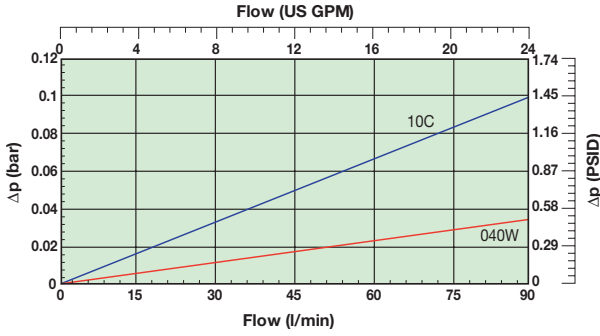

**TTF90 Filter Element Length 3  
Cellulose & stainless steel media**

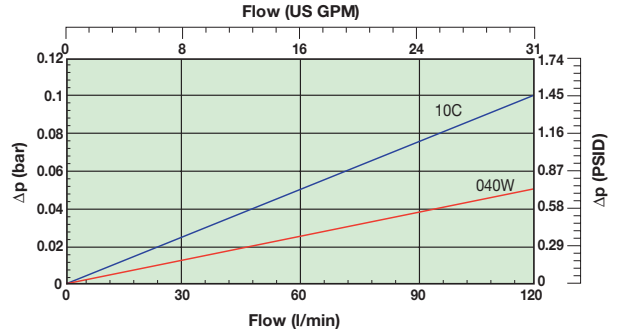

**TTF120 Filter Element Length 4  
Cellulose & stainless steel media**

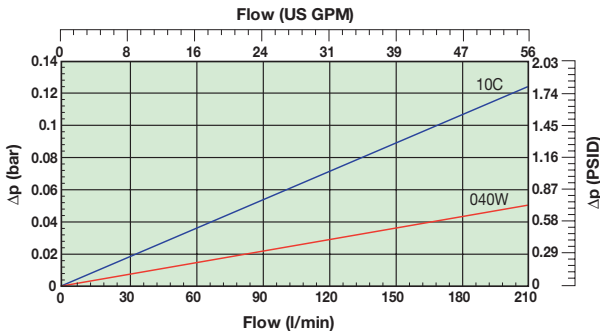

**TTF125 Filter Element Length 5  
Cellulose & stainless steel media**

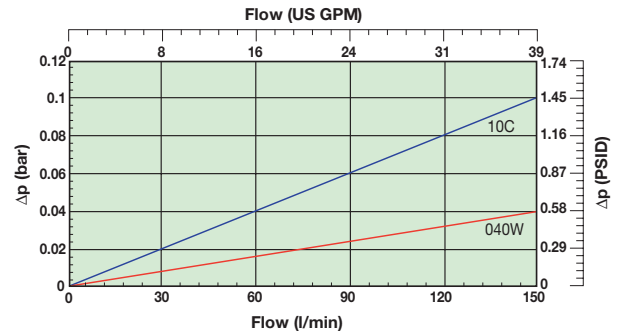

**TTF170 Filter Element Length 6  
Cellulose & stainless steel media**

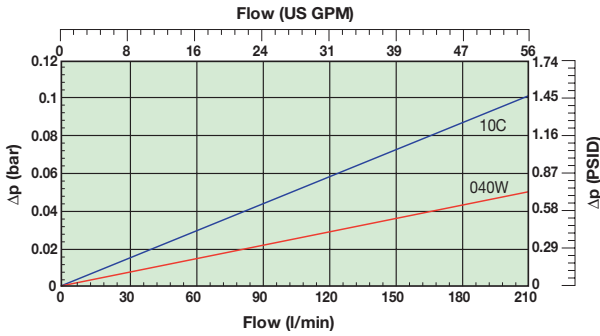

**TTF230 Filter Element Length 7  
Cellulose & stainless steel media**

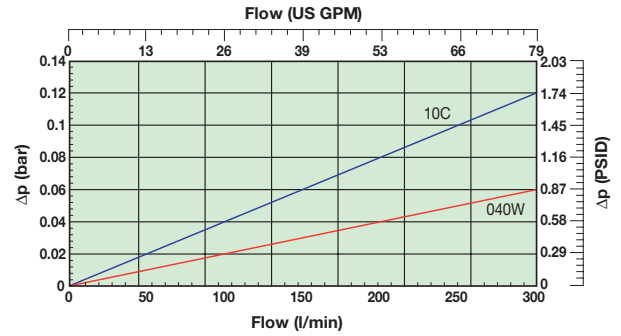

**TTF300 Filter Element Length 8  
Cellulose & stainless steel media**

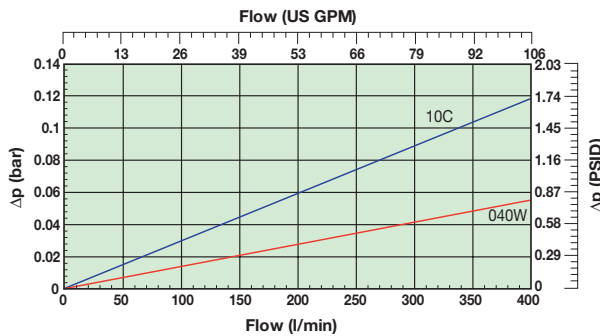

## Tanktop Mounted Return Line Filters

# TTF Series

### Indicator Options

#### Indicator PS pressure switch

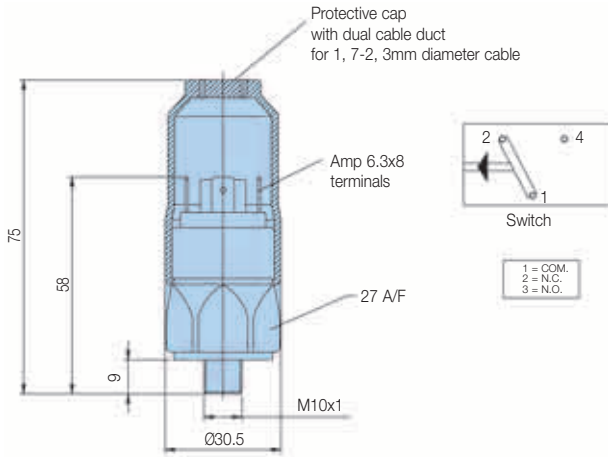

Specifications	
Elec.rating	42V / 4A
Thread connection	M10x1
Elec.connection	AMP 6.3x0.8 terminals + protective cap
Protection	IP65 (with cap) terminals IP00
Code	FMUS1EBMM10L (Switch)

#### Indicator PS NO/NC pressure switch

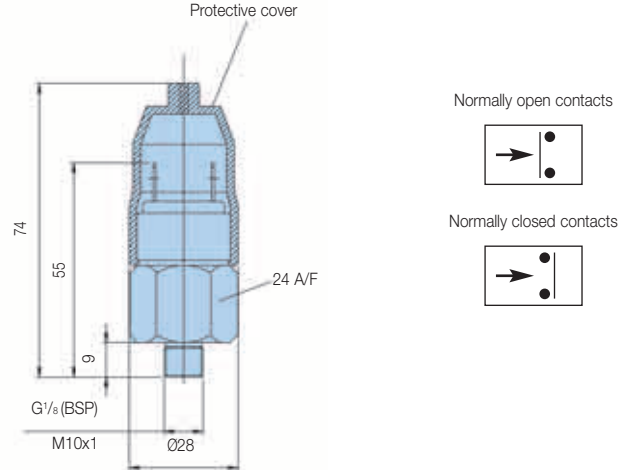

Specifications	
Elec.rating	42V / 2A
Thread connection	G1/8 - M10x1
Elec.connection	AMP terminal 6.3x0.8
Protection	IP65 (terminal IP00)
Switch type	NO or NC
Code	FMUS2EBMG02L (NO switch) FMUS3EBMG02L (NC switch)

Visual indicator	
Visual indicator	1.2 bar
M10: code	FMUG1EBPM10L
G1/8: code	FMUG2EBPG02L

### Ordering Information

#### Standard products table

Part number	Supercedes	Flow (l/min)	Model number	Element length	Media rating (µ)	Seals	Indicator	Bypass settings	Ports	Included options	Replacement elements	Supercedes
TTF310QLBP2EG121	TTF90-G <sup>3</sup> / <sub>4</sub> TXWL3-10 B15 MM	90	TTF90	Length 3	10	Nitrile	Plugged	1.5 Bar (22 Psi)	G <sup>3</sup> / <sub>4</sub>	None	937878Q	TXWL3-10
TTF320QLBP2EG121	TTF90-G <sup>3</sup> / <sub>4</sub> TXWL3-20 B15 MM	90	TTF90	Length 3	20	Nitrile	Plugged	1.5 Bar (22 Psi)	G <sup>3</sup> / <sub>4</sub>	None	937877Q	TXWL3-20
TTF510QLBP2EG161	TTF125-G1 TXWL3E-10 B15 MM	125	TTF125	Length 5	10	Nitrile	Plugged	1.5 Bar (22 Psi)	G1	None	937852Q	TXWL3E-10
TTF520QLBP2EG161	TTF125-G1 TXWL3E-20 B15 MM	125	TTF125	Length 5	20	Nitrile	Plugged	1.5 Bar (22 Psi)	G1	None	937875Q	TXWL3E-20
TTF610QLBP2EG203	TTF170-G1 <sup>1</sup> / <sub>4</sub> TXWL4-10 T B15 MM	170	TTF170	Length 6	10	Nitrile	Plugged	1.5 Bar (22 Psi)	G1 <sup>1</sup> / <sub>4</sub>	Diffuser type T	937853Q	TXWL4-10
TTF620QLBP2EG203	TTF170-G1 <sup>1</sup> / <sub>4</sub> TXWL4-20 T B15 MM	170	TTF170	Length 6	20	Nitrile	Plugged	1.5 Bar (22 Psi)	G1 <sup>1</sup> / <sub>4</sub>	Diffuser type T	937874Q	TXWL4-20
TTF810QLBP2EG243	TTF300-G1 <sup>1</sup> / <sub>2</sub> TXWL5A-10 T B15 MM	300	TTF300	Length 8	10	Nitrile	Plugged	1.5 Bar (22 Psi)	G1 <sup>1</sup> / <sub>2</sub>	Diffuser type T	937855Q	TXWL5A-10
TTF820QLBP2EG243	TTF300-G1 <sup>1</sup> / <sub>2</sub> TXWL5A-20 T B15 MM	300	TTF300	Length 8	20	Nitrile	Plugged	1.5 Bar (22 Psi)	G1 <sup>1</sup> / <sub>2</sub>	Diffuser type T	937872Q	TXWL5A-20
TTF1010QLBP2HG24A	TTF500-G1 <sup>1</sup> / <sub>2</sub> TXWL5C-10 T B20 MM NMG	500	TTF500	Length 10	10	Nitrile	Plugged	2.0 Bar (29 Psi)	G1 <sup>1</sup> / <sub>2</sub>	Diffuser type T	937857Q	TXWL5C-10
TTF1010QLBP2HG24A	TTF500-G1 <sup>1</sup> / <sub>2</sub> TXWL5C-20 T B20 MM NMG	500	TTF500	Length 10	20	Nitrile	Plugged	2.0 Bar (29 Psi)	G1 <sup>1</sup> / <sub>2</sub>	Diffuser type T	937870Q	TXWL5C-20

Note: Filter assemblies ordered from the product configurator on the next page are on extended lead times. Where possible, please make your selection from the table above.



## Ordering Information (cont.)

### Product configurator

#### Configurator example of a TTF Series filter

Box 1	Box 2	Box 3	Box 4	Box 5	Box 6	Box 7	Box 8
<b>TTF</b>	<b>9</b>	<b>05QL</b>	<b>V</b>	<b>S3</b>	<b>H</b>	<b>L24</b>	<b>1</b>

#### Configurator example of a TSR Series filter

Box 1	Box 2	Box 3	Box 4	Box 5	Box 6	Box 7	Box 8
<b>TSR</b>	<b>3</b>	<b>20QL</b>	<b>B</b>	<b>G2</b>	<b>E</b>	<b>2G20</b>	<b>3</b>

Box 1	Box 2	Box 3
<b>Code</b>	<b>Filter type</b>	<b>Degree of filtration</b>
<b>TTF</b>	<b>Housing</b>	<b>Element media</b>
TSR	<b>Code</b>	<b>Glass fibre</b>
	TTF 1-60	Microglass III (for disposable elements)
	TTF 1-90	Ecoglass III (for Leif® elements)
	TTF 1-120	<b>Cellulose</b>
	TTF 1-125	Nom. rating
	TTF 2-170	2µ media
	TTF 2-230	5µ media
	TTF 2-300	10µ media
	TTF 2-400	20µ media
	TTF 2-500	<b>Wire mesh</b>
	TSR2-120	Abs. rating
	TSR2-200	040W
	TSR2-250	
		<b>Disposable element</b>
		10C
		<b>LEIF® element</b>
		02QL
		05QL
		10QL
		20QL

Box 4
<b>Seal type</b>
<b>Seal material</b>
<b>Code</b>
Nitrile
B
Fluorelastomer
V
Neoprene
N

Box 5
<b>Indicator</b>
<b>Code</b>
Pressure gauge, setting 1.2 bar, M10x1
G1
Pressure gauge, setting 1.2 bar, G $\frac{1}{8}$ for dual head ports and TSR series
G2
Pressure switch 42V, 1.2 bar setting, NO/NC, M10x1
S1
Pressure switch 42V, 1.2 bar setting, NO with G $\frac{1}{8}$ BSP
S2
Pressure switch 42V, 1.2 bar setting, NC with G $\frac{1}{8}$ BSP
S3
Pressure switch 250V, NO/NC with G $\frac{1}{8}$
S4
Pressure switch 220V, NO/NC with M10
S5
No indicator, indicator ports not machined
N
No indicator, indicator port R plugged
P
No indicator, indicator ports L + R plugged
P2
Other settings for indicators / gauges on request
on request

Box 6
<b>Bypass valve</b>
<b>Bypass valve</b>
<b>Code</b>
0.8 bar
B
1.5 bar
E
2.0 bar for TTF series
H
Blocked bypass
X
Other bypass settings
on request

Box 7
<b>Filter connection</b>
<b>Ports</b>
<b>Code</b>
G $\frac{1}{4}$ " (BSP) (1-60/1-90/1-120)
G12
G1" (BSP) (1-60/1-90/1-120)
G16
G1 $\frac{1}{4}$ " (BSP) (2-170/2-230/2-300/2-400/2-500)
G20
G1 $\frac{1}{2}$ "(BSP) (2-170/2-230/2-300/2-400/2-500)
G24
1 $\frac{1}{2}$ " SAE-3000 PSI (2nd port) + G1 $\frac{1}{2}$ "
L24
G2" (2nd port) + G1 $\frac{1}{2}$ "
G32
G1 $\frac{1}{4}$ " (BSP) + 2 Ports G1" (TSR only)
G20
2xG1 $\frac{1}{2}$ " (BSP) + 2 Ports G1" (TSR only)
2G20
SAE20 + 2 Ports A SAE16 (TSR only)
S20
2xSAE20 + 2 Ports SAE16 (TSR only)
2S20

Box 8
<b>Options</b>
<b>Options</b>
<b>Code</b>
No diffuser required
1
Diffuser type T with perforated plate area
3
Diffuser type P without perforated plate area
4
Diffuser with integrated hose connection
on request
No magnets
5
Dipstick
6
Plugged filling port
8
Diffuser type T and no magnets
A
Diffuser type P and no magnets
B
Diffuser type T, no magnets, plugged filling port
C
Diffuser type P, no magnets, plugged filling port
D
Other combinations
on request

Note 1: Part numbers featured with bold highlighted codes will ensure a 'standard' product selection.  
 Note 2: Alternate displayed part number selection will require you to contact Parker Filtration for availability.

<b>Degree of filtration</b>						<b>Media code</b>
Average filtration beta ratio $\beta$ (ISO 16889) / particle size $\mu$ m [c]						
$\beta$ x(c)=2	$\beta$ x(c)=10	$\beta$ x(c)=75	$\beta$ x(c)=100	$\beta$ x(c)=200	$\beta$ x(c)=1000	
% efficiency, based on the above beta ratio ( $\beta$ x)						
50.0%	90.0%	98.7%	99.0%	99.5%	99.9%	
N/A	N/A	N/A	N/A	N/A	4.5	
N/A	N/A	4.5	5	6	7	
N/A	6	8.5	9	10	12	
6	11	17	18	20	22	
						02Q/02QL
						05Q/05QL
						10Q/10QL
						20Q/20QL

#### Highlights Key (Denotes part number availability)

<b>123</b>	Item is standard
123	Item is standard with "green" options
<b>123</b>	Item is semi standard
123	Item is non standard

Note: Standard items are in stock, semi standard items are available within four weeks

## Tanktop Mounted Return Line Filters

# TTF Series

### Ordering Information (cont.)

**Supersedes spare element table**

TTF 1-60	TXWL2-2	TXWL2-5	TXWL2-10	TXWL2-20
Part number spare element	937823Q	937880Q	937881Q	937882Q
TTF 1-90	TXWL3-2	TXWL3-5	TXWL3-10	TXWL3-20
Part number spare element	937824Q	937879Q	937878Q	937877Q
TTF 1-120	TXWL3D-2	TXWL3D-5	TXWL3D-10	TXWL3D-20
Part number spare element	937825Q	937825Q	937851Q	937876Q
TTF 1-125	TXWL3E-2	TXWL3E-5	TXWL3D-10	TXWL3E-20
Part number spare element	937826Q	937849Q	937852Q	937875Q
TTF 1-170	TXWL4-2	TXWL4-5	TXWL4-10	TXWL4-20
Part number spare element	937827Q	937848Q	937853Q	937874Q
TTF 1-230	TXWL5-2	TXWL5-5	TXWL5-10	TXWL5-20
Part number spare element	937828Q	937847Q	937854Q	937873Q
TTF 1-300	TXWL5A-2	TXWL5A-5	TXWL5A-10	TXWL5A-20
Part number spare element	937829Q	937846Q	937855Q	937872Q
TTF 1-400	TXWL5B-2	TXWL5B-5	TXWL5B-10	TXWL5B-20
Part number spare element	937830Q	937845Q	937856Q	937871Q
TTF 1-500	TXWL5C-2	TXWL5C-5	TXWL5C-10	TXWL5C-20
Part number spare element	937831Q	937844Q	937857Q	937870Q
TSR120	PXWL3-2	PXWL3-5	PXWL3-10	PXWL3-20
Part number spare element	937886Q	937889Q	937892Q	937895Q
TSR200	PXWL4-2	PXWL4-5	PXWL4-10	PXWL4-20
Part number spare element	937887Q	937890Q	937893Q	937896Q
TSR250	PXWL4A-2	PXWL4A-5	PXWL4A-10	PXWL4A-20
Part number spare element	937888Q	937891Q	937894Q	937897Q

**Supersedes spare element table**

TTF 1-60	TXX2-10-B	TXW2-2-B	TXW2-5-B	TXW2-10-B	TXW2-20-B	ST2-40-B
Part number spare element	937721	937751Q	937754Q	937787Q	937790Q	937820
TTF 1-90	TXX3-10-B	TXW3-2-B	TXW3-5-B	TXW3-10-B	TXW3-20-B	ST3-40-B
Part number spare element	937722	937750Q	937755Q	937786Q	937791Q	937819
TTF 1-120	TXX3D-10-B	TXW3D-2-B	TXW3D-5-B	TXW3D-10-B	TXW3D-20-B	ST3D-40-B
Part number spare element	937723	937749Q	937756Q	937785Q	937792Q	937818
TTF 1-125	TXX3E-10-B	TXW3E-2-B	TXW3E-5-B	TXW3E-10-B	TXW3E-20-B	ST3E-40-B
Part number spare element	937724	937748Q	937757Q	937748Q	937793Q	937817
TTF 1-170	TXX4-10-B	TXW4-2-B	TXW4-5-B	TXW4-10-B	TXW4-20-B	ST4-40-B
Part number spare element	937725	937747Q	937758Q	937783Q	937794Q	937816
TTF 1-230	TXX5-10-B	TXW5-2-B	TXW5-5-B	TXW5-10-B	TXW5-20-B	ST5-40-B
Part number spare element	937726	937746Q	937759Q	937782Q	937795Q	937815
TTF 1-300	TXX5A-10-B	TXW5A-2-B	TXW5A-5-B	TXW5A-10-B	TXW5A-20-B	ST5A-40-B
Part number spare element	937727	937745Q	937760Q	937781Q	937796Q	937814