



High Pressure Filters

# 70/70 Eco Series

MAX 450 l/min - 420 bar

FEATURING  
**EC GLASS III**



# 70/70 Eco Series

## Features & Benefits

Features	Advantages	Benefits
Fatigue tested to full pressure rating	Strong and robust housing for heavy duty applications	Reliable and continuous operation both in mobile and industrial applications
Several head options and connection sizes	Easy mounting	Reduced space and piping Right filter for each application
Several bowl lengths	Optimised sizing	Efficient filtration
Microglass III replacement elements	Multi-layered design produced high capacity and efficiency	Great performance value
	Wire support reduces pleat bunching, keeps performance consistent	Reliable performance throughout element life Reduces downtime, maximises element life
Coreless Ecoglass III replacement elements	No metal content in element	Environmentally friendly disposal by incineration
	Reduced overall weight of 50%	Lower element replacement costs
	Easy compaction of used elements	Lower disposal costs
	Eco adaptors available	Retrofit coreless design to housings already installed
Visual, electrical and electronic indicators available	Check element condition at a glance	Optimise element life, prevent bypassing
	Right style for the application	Matches your system electrical connections

## Typical Applications

- Forestry equipment
- Industrial power units
- Pulp and paper
- Port handling equipment
- Mining and quarrying equipment

### The Parker Filtration 70/70 Eco Series High Pressure Filters.

High quality 420 bar in-line pressure filters designed to offer high levels of protection at flows up to 450 l/min.

Dirt sensitive systems can be protected with confidence using the 70 Series high pressure filters.

The 70 Series also available with environmentally friendly Ecoglass III elements.



## Specification

### Pressure ratings:

Maximum allowable operating pressure 420 bar.  
Filter housing pressure pulse fatigue tested:  $10^6$  pulses 0 - 414 bar.

### Connections:

Threads G1, G1 $\frac{1}{4}$ , G1 $\frac{1}{2}$  (ISO 228/1).  
or flanges 1 $\frac{1}{4}$ " SAE 3000-M, 1 $\frac{1}{2}$ " SAE 3000-M, 1 $\frac{1}{4}$ " SAE 6000-M,  
1 $\frac{1}{2}$ " SAE 6000-M.

### Filter housing:

Head material cast iron (GSI).  
Bowl material steel. Max torque 40 Nm.

### Seal material:

Nitrile or Fluoroelastomer.

### Operating temperature range:

- 30°C to +100°C.

### Bypass valve:

Opening pressure 3.5 bar.

### Filter element:

#### Degree of filtration:

Determined by Multipass-test according to ISO 16889.

#### Flow fatigue characteristics:

Filter media is supported so that the optimal fatigue life is achieved (ISO 3724).

### Microglass III:

Supported with epoxy coated metal wire mesh, end cap material reinforced composite and metal inner core.  
Collapse rating 20 bar (ISO 2941).

### Ecoglass III:

Supported with plastic net, end cap material reinforced composite.  
No metal parts.

Collapse rating 10 bar (ISO 2941).

Filter element can only be used together with reusable FEA Eco-adapter.

Note: Ecoglass III contributes to ISO 14001 quality.

### High collapse elements:

(To be used when no bypass function in filter housing).

Microglass III media supported with epoxy coated metal wire mesh on upstream and stainless steel on downstream, end cap material steel. Strong metal inner core. Collapse rating 210 bar (ISO 2941).

### Indicator options:

Indicating differential pressure:  $2.5 \pm 0.3$  bar or  $7.0 \pm 0.5$  bar.

2.5 bar indicators to be used with 3.5 bar bypass valve and 7.0 bar indicators with no bypass function.

- visual M3.
- electrical T1.
- electronic F1(PNP).
- electronic F2(NPN).

For indicator details see catalogue section 6.

### Fluid compatibility:

Suitable for use with mineral and vegetable oils, and some synthetic oils. For other fluids, please consult Parker Filtration.

# 70/70 Eco Series

## Specification

**70B**

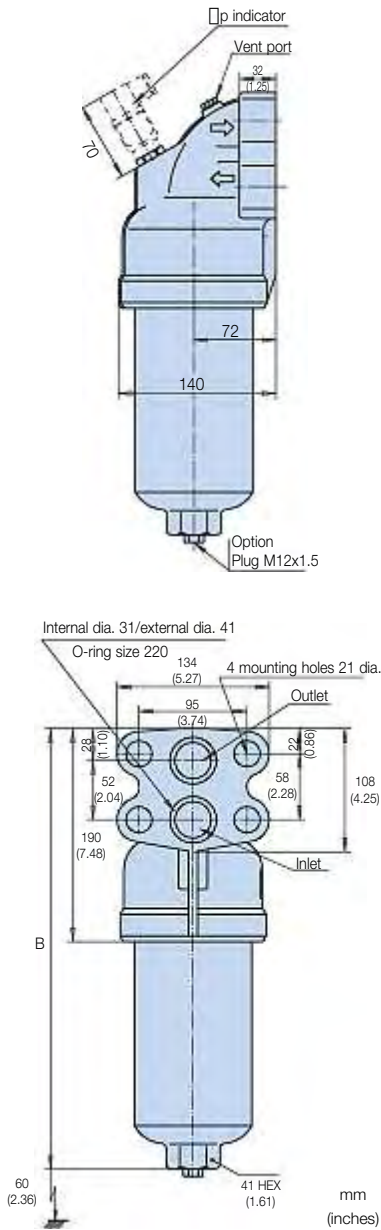

**70T**

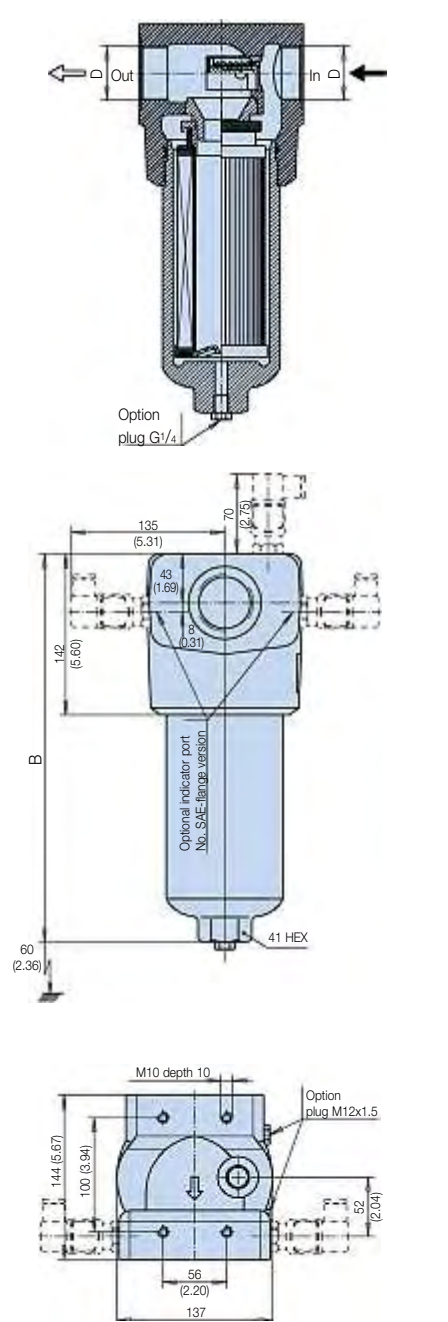

**70L**

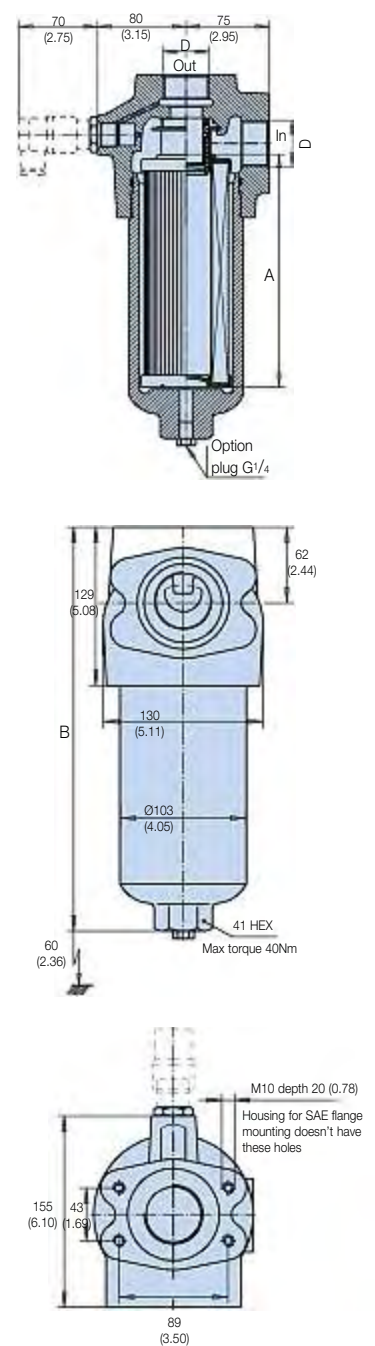

**Weights (kg)**

Type	70T	70L	70B
Length 1	14	10.5	11.5
Length 2	16.5	13	14
Length 3	19	15.5	16.5
Length 4	22	18.5	19.5

Type	A	B 70T	B 70B	B 70L	Max working pressure	Port D
Length 1	116 (4.57)	249 (9.80)	295 (11.61)	235 (9.25)	420 bar	G1, G1 <sup>1</sup> / <sub>4</sub> or G1 <sup>1</sup> / <sub>2</sub> Flange 1 <sup>1</sup> / <sub>2</sub> SAE 3000-M Flange 1 <sup>1</sup> / <sub>4</sub> SAE 3000-M Flange 1 <sup>1</sup> / <sub>2</sub> SAE 6000-M Flange 1 <sup>1</sup> / <sub>4</sub> SAE 6000-M
Length 2	208 (8.19)	342 (13.46)	390 (15.35)	330 (13.00)		
Length 3	329 (12.95)	462 (18.19)	510 (20.08)	450 (17.72)		
Length 4	428 (16.85)	562 (22.12)	610 (24.01)	550 (21.65)	350 bar	

## Pressure Drop Curves

With 3.5 bar bypass the recommended initial pressure drop is max 1.2 bar.

If the medium used has a viscosity different from 30 cSt, pressure drop over the filter can be estimated as follows:

The total  $\Delta p = \text{housing } \Delta p_h + (\text{element } \Delta p_e \times \text{working viscosity}/30)$ .

### 70 Series Empty Housing

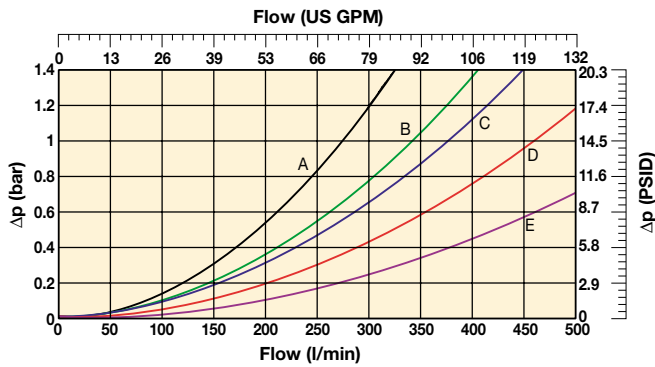

- A: 70T with G16 connections
- B: 70T with G20 connections
- C: 70L with G16 connections
- D: 70T with G24 connections
- E: 70L with G24 connections

### 70-1 Elements with Microglass III

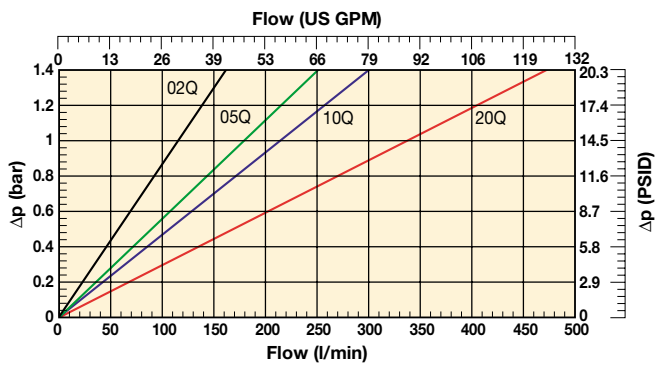

### 70-2 Elements with Microglass III

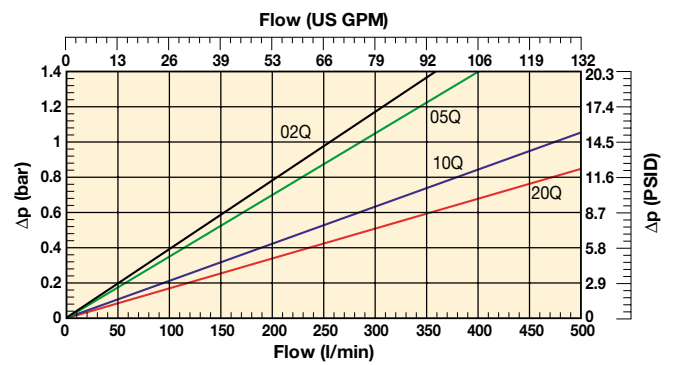

### 70-3 Elements with Microglass III

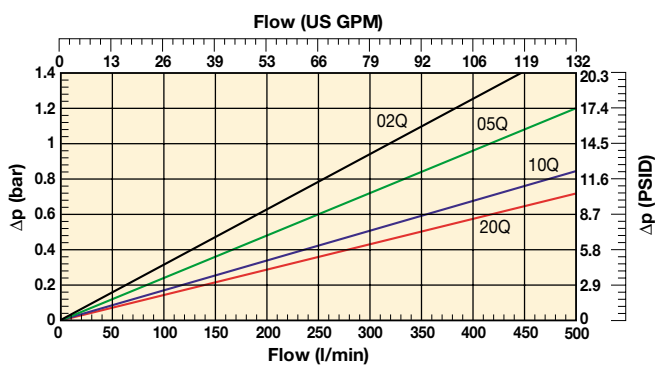

### 70-4 Elements with Microglass III

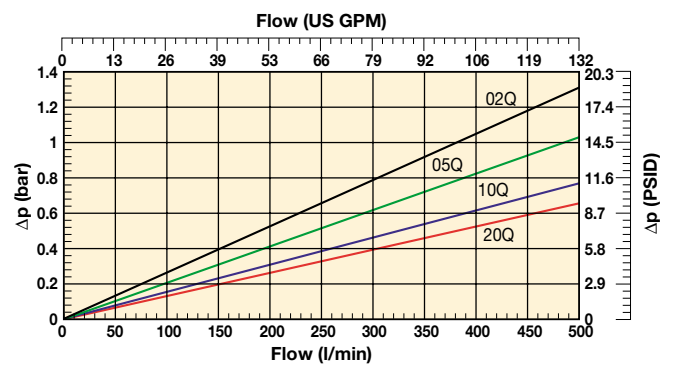

# 70/70 Eco Series

Pressure Drop Curves (cont.)

70-1 Elements with Ecoglass III

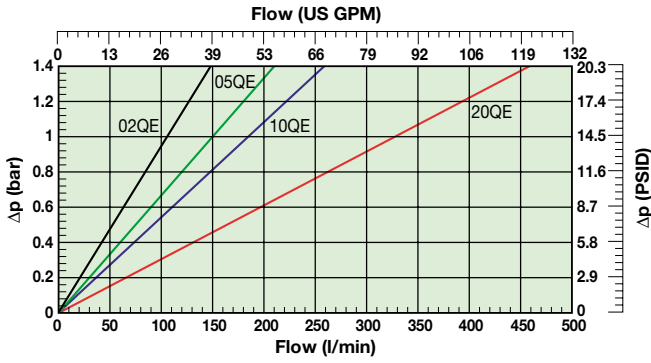

70-2 Elements with Ecoglass III

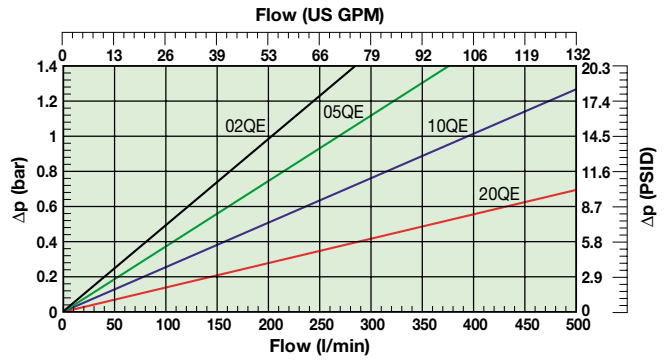

70-3 Elements with Ecoglass III

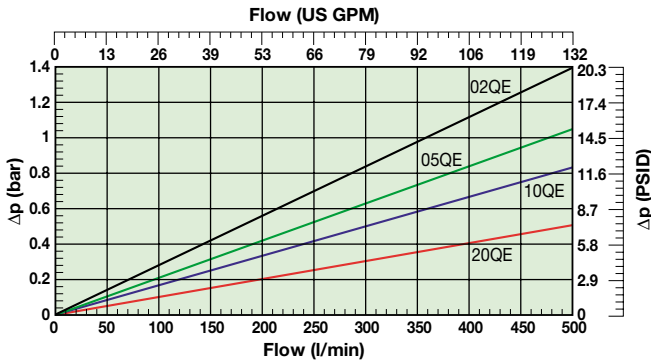

70-4 Elements with Ecoglass III

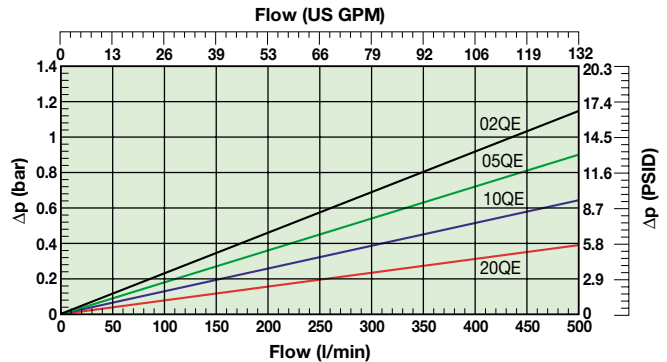

## Ordering Information

Standard products table

Part number	Supersedes	Flow (l/min)	Model number	Element length	Media rating (µ)	Seals	Indicator	Bypass settings	Ports	Replacement elements	Supersedes
70L110QBPKG161	FF7005.Q010.BS35.GL16	150	70L	1	10	Nitrile	Plugged	3.5 bar	G1"	938773Q	FC7005.Q010.BK
70L120QBPKG161	FF7005.Q020.BS35.GL16	230	70L	1	20	Nitrile	Plugged	3.5 bar	G1"	938774Q	FC7005.Q020.BK
70L210QBPKG201	FF7006.Q010.BS35.GL20	280	70L	2	10	Nitrile	Plugged	3.5 bar	G1 1/4"	938777Q	FC7006.Q010.BK
70L220QBPKG201	FF7006.Q020.BS35.GL20	300	70L	2	20	Nitrile	Plugged	3.5 bar	G1 1/4"	938778Q	FC7006.Q020.BK
70L310QBPKG241	FF7007.Q010.BS35.GL24	400	70L	3	10	Nitrile	Plugged	3.5 bar	G1 1/2"	938781Q	FC7007.Q010.BK
70L320QBPKG241	FF7007.Q020.BS35.GL24	430	70L	3	20	Nitrile	Plugged	3.5 bar	G1 1/2"	938782Q	FC7007.Q020.BK
70L410QBPKG241	FF7008.Q010.BS35.GL24	430	70L	4	10	Nitrile	Plugged	3.5 bar	G1 1/2"	938785Q	FC7008.Q010.BK
70L420QBPKG241	FF7008.Q020.BS35.GL24	450	70L	4	20	Nitrile	Plugged	3.5 bar	G1 1/2"	938786Q	FC7008.Q020.BK
70L110QEBPKG161	FF7005.QE10.BS35.GL16	150	70L	1	10	Nitrile	Plugged	3.5 bar	G1"	938789Q	FC7005.QE10.BK
70L120QEBPKG161	FF7005.QE20.BS35.GL16	230	70L	1	20	Nitrile	Plugged	3.5 bar	G1"	938790Q	FC7005.QE20.BK
70L210QEBPKG201	FF7006.QE10.BS35.GL20	280	70L	2	10	Nitrile	Plugged	3.5 bar	G1 1/4"	938793Q	FC7006.QE10.BK
70L220QEBPKG201	FF7006.QE20.BS35.GL20	300	70L	2	20	Nitrile	Plugged	3.5 bar	G1 1/4"	938794Q	FC7006.QE20.BK
70L310QEBPKG241	FF7007.QE10.BS35.GL24	400	70L	3	10	Nitrile	Plugged	3.5 bar	G1 1/2"	938797Q	FC7007.QE10.BK
70L320QEBPKG241	FF7007.QE20.BS35.GL24	430	70L	3	20	Nitrile	Plugged	3.5 bar	G1 1/2"	938798Q	FC7007.QE20.BK
70L410QEBPKG241	FF7008.QE10.BS35.GL24	430	70L	4	10	Nitrile	Plugged	3.5 bar	G1 1/2"	938801Q	FC7008.QE10.BK
70L420QEBPKG241	FF7008.QE20.BS35.GL24	450	70L	4	20	Nitrile	Plugged	3.5 bar	G1 1/2"	938802Q	FC7008.QE20.BK
70T110QBPKG161	FF7005.Q010.BS35.GT16	150	70T	1	10	Nitrile	Plugged	3.5 bar	G1"	938773Q	FC7005.Q010.BK
70T120QBPKG161	FF7005.Q020.BS35.GT16	200	70T	1	20	Nitrile	Plugged	3.5 bar	G1"	938774Q	FC7005.Q020.BK
70T210QBPKG201	FF7006.Q010.BS35.GT20	260	70T	2	10	Nitrile	Plugged	3.5 bar	G1 1/4"	938777Q	FC7006.Q010.BK
70T220QBPKG201	FF7006.Q020.BS35.GT20	280	70T	2	20	Nitrile	Plugged	3.5 bar	G1 1/4"	938778Q	FC7006.Q020.BK
70T310QBPKG241	FF7007.Q010.BS35.GT24	360	70T	3	10	Nitrile	Plugged	3.5 bar	G1 1/2"	938781Q	FC7007.Q010.BK
70T320QBPKG241	FF7007.Q020.BS35.GT24	380	70T	3	20	Nitrile	Plugged	3.5 bar	G1 1/2"	938782Q	FC7007.Q020.BK
70T410QBPKG241	FF7008.Q010.BS35.GT24	360	70T	4	10	Nitrile	Plugged	3.5 bar	G1 1/2"	938785Q	FC7008.Q010.BK
70T420QBPKG241	FF7008.Q020.BS35.GT24	380	70T	4	20	Nitrile	Plugged	3.5 bar	G1 1/2"	938786Q	FC7008.Q020.BK
70T110QEBPKG161	FF7005.QE10.BS35.GT16	150	70T	1	10	Nitrile	Plugged	3.5 bar	G1"	938789Q	FC7005.QE10.BK
70T120QEBPKG161	FF7005.QE20.BS35.GT16	200	70T	1	20	Nitrile	Plugged	3.5 bar	G1"	938790Q	FC7005.QE20.BK
70T210QEBPKG201	FF7006.QE10.BS35.GT20	260	70T	2	10	Nitrile	Plugged	3.5 bar	G1 1/4"	938793Q	FC7006.QE10.BK
70T220QEBPKG201	FF7006.QE20.BS35.GT20	280	70T	2	20	Nitrile	Plugged	3.5 bar	G1 1/4"	938794Q	FC7006.QE20.BK
70T310QEBPKG241	FF7007.QE10.BS35.GT24	360	70T	3	10	Nitrile	Plugged	3.5 bar	G1 1/2"	938797Q	FC7007.QE10.BK
70T320QEBPKG241	FF7007.QE20.BS35.GT24	380	70T	3	20	Nitrile	Plugged	3.5 bar	G1 1/2"	938798Q	FC7007.QE20.BK
70T410QEBPKG241	FF7008.QE10.BS35.GT24	360	70T	4	10	Nitrile	Plugged	3.5 bar	G1 1/2"	938801Q	FC7008.QE10.BK
70T420QEBPKG241	FF7008.QE20.BS35.GT24	380	70T	4	20	Nitrile	Plugged	3.5 bar	G1 1/2"	938802Q	FC7008.QE20.BK

Note: Filter assemblies ordered from the product configurator on next page are on extended lead times. Where possible, please make your selection from the table above.

# 70/70 Eco Series

## Ordering Information (cont.)

### Product configurator

Box 1	Box 2	Box 3	Box 4	Box 5	Box 6	Box 7	Box 8
<b>70L</b>	<b>3</b>	<b>10Q</b>	<b>B</b>	<b>M3</b>	<b>K</b>	<b>G24</b>	<b>1</b>

Box 1		Box 2		Box 3			
Code		Filter type		Degree of filtration			
<b>Model</b>	<b>Code</b>	<b>Length</b>	<b>Code</b>	Element media	<b>Glass fibre</b>		
High pressure filter with L-port	<b>70L</b>	Length 1	<b>1</b>		<b>Media code</b>		
High pressure filter with T-port	<b>70T</b>	Length 2	<b>2</b>	Microglass III element	<b>02Q</b>	<b>05Q</b>	<b>10Q</b>
High pressure filter with side manifold mounting	70B	Length 3	<b>3</b>	Ecoglass III element	<b>02QE</b>	<b>05QE</b>	<b>10QE</b>
		Length 4	<b>4</b>	High collapse element	02QH	05QH	10QH
							20QH

Note: When using Ecoglass III elements reusable Eco-adaptor is required

Box 4		Box 5		Box 6		
Seal type		Indicator		Bypass and indicator settings		
<b>Seal material</b>	<b>Code</b>		<b>Code</b>	<b>Bypass valve</b>	<b>Indicator</b>	<b>Code</b>
Nitrile	<b>B</b>	Plugged with steel plug	<b>P</b>	3.5 bar	2.5 bar	<b>K</b>
Fluoroelastomer	V	Visual indicator	<b>M3</b>	No bypass	7.0 bar	N
		Electrical indicator	<b>T1</b>	No bypass	No indicator (P)	X
		Electronic 4 LED, PNP, N.O.	F1			
		Electronic 4 LED, NPN, N.O.	F2			
		Electronic 4 LED, PNP, N.C.	F3			
		Electronic 4 LED, NPN, N.C.	F4			

+ Box 8: code 2  
+ Box 8: code 2

When filter includes a bypass valve but not an indicator, code denotes bypass setting.

Box 7					
Filter connection					
<b>Connections</b>	<b>Code</b>	Length 1	Length 2	Length 3	Length 4
Thread G 1	<b>G16</b>	<b>S</b>	<b>S</b>	x	x
Thread G 1 1/4	<b>G20</b>	<b>S</b>	<b>S</b>	<b>S</b>	<b>S</b>
Thread G 1 1/2	<b>G24</b>	x	<b>S</b>	<b>S</b>	<b>S</b>
SAE flange 1 1/4" 3000-M	R20	x	x	x	x
SAE flange 1 1/2" 3000-M	R24	x	x	x	x
SAE flange 1 1/4" 6000-M	H20	x	x	x	x
SAE flange 1 1/2" 6000-M	H24	x	x	x	x
Side manifold (70B only)	X32	x	x	x	x

Availability: **S** = standard product  
x = non-standard, ask for availability

Box 8	
Options	
<b>Options</b>	<b>Code</b>
Standard	<b>1</b>
No bypass	2
Drain port	4
70T: side indicator ports	6
70T: options 2 + 6	8

Options 6 and 8: in 70T model there is an option for 2 x indicator ports on filter outlet flange (standard indicator port not machined)  
P: both side indicator ports plugged with steel plug  
M3 or other indicator chosen: right side (in flow direction) port plugged with a plastic plug, left with a steel plug

Nominal flow (l/min) at viscosity 30 cSt						
Filter length	Media	G16 L-port & G20 T-port				
		G16 T-port	G20 T-port	G20 L-port & Side manifold	G24 T-port	G24 L-port
Length 1	02Q/02QE	80	80	80	80	80
	05Q/05QE	120	120	120	120	120
	10Q/10QE	150	150	150	150	150
	20Q/20QE	200	230	230	230	230
Length 2	02Q/02QE	160	160	160	160	160
	05Q/05QE	180	200	200	200	200
	10Q/10QE	220	260	280	300	320
	20Q/20QE	240	280	300	330	350
Length 3	02Q/02QE	200	220	220	220	220
	05Q/05QE	220	250	280	280	280
	10Q/10QE	240	280	300	350	400
	20Q/20QE	250	300	320	380	430
Length 4	02Q/02QE	220	250	270	270	270
	05Q/05QE	230	260	300	330	330
	10Q/10QE	250	280	330	360	430
	20Q/20QE	260	300	350	380	450

Replacement elements with nitrile seals				
Media	Length 1	Length 2	Length 3	Length 4
02Q	<b>938771Q</b>	<b>938775Q</b>	<b>938779Q</b>	<b>938783Q</b>
05Q	<b>938772Q</b>	<b>938776Q</b>	<b>938780Q</b>	<b>938784Q</b>
10Q	<b>938773Q</b>	<b>938777Q</b>	<b>938781Q</b>	<b>938785Q</b>
20Q	<b>938774Q</b>	<b>938778Q</b>	<b>938782Q</b>	<b>938786Q</b>
02QE	<b>938787Q</b>	<b>938791Q</b>	<b>938795Q</b>	<b>938799Q</b>
05QE	<b>938788Q</b>	<b>938792Q</b>	<b>938796Q</b>	<b>938800Q</b>
10QE	<b>938789Q</b>	<b>938793Q</b>	<b>938797Q</b>	<b>938801Q</b>
20QE	<b>938790Q</b>	<b>938794Q</b>	<b>938798Q</b>	<b>938802Q</b>
02QH	938803Q	938807Q	938811Q	938815Q
05QH	938804Q	938808Q	938812Q	938816Q
10QH	938805Q	938809Q	938813Q	938817Q
20QH	938806Q	938810Q	938814Q	938818Q

**Highlights Key (Denotes part number availability)**

<b>123</b>	Item is standard
<b>123</b>	Item is standard green option
<b>123</b>	Item is semi standard
123	Item is non standard

Note: Standard items are in stock, semi standard items are available within four weeks

Degree of filtration						Code		
Average filtration beta ratio β (ISO 16889) / particle size μm [c]						Disposable Microglass III	Metal free Ecoglass III	High collapse element
βx(c)=2	βx(c)=10	βx(c)=75	βx(c)=100	βx(c)=200	βx(c)=1000			
% efficiency, based on the above beta ratio (βx)								
<b>50.0%</b>	<b>90.0%</b>	<b>98.7%</b>	<b>99.0%</b>	<b>99.5%</b>	<b>99.9%</b>			
N/A	N/A	N/A	N/A	N/A	4.5	<b>02Q</b>	<b>02QE</b>	02QH
N/A	N/A	4.5	5	6	7	<b>05Q</b>	<b>05QE</b>	05QH
N/A	6	8.5	9	10	12	<b>10Q</b>	<b>10QE</b>	10QH
6	11	17	18	20	22	<b>20Q</b>	<b>20QE</b>	20QH

Note 1: Part numbers featured with bold highlighted codes will ensure a 'standard' product selection.  
Note 2: Alternate displayed part number selection will require you to contact Parker Filtration for availability.

